



Company website:

[Http://www.aqldsj.com](http://www.aqldsj.com)

The most comprehensive information website of forklift fittings related products in China



Good helper of forklift truck  
Liandong Engineering Trucks

Anqing liandong Engineering Trucks Attachments Co., Ltd.

Add: No. 16 Fangxing Road, High-tech Zone, Economic and Technological  
Development Zone, Anqing, Anhui, China

Tel: 0556-5228123

Fax: 0556-5345491

Url: [www.aqldsj.com](http://www.aqldsj.com)

Anqing liandong Engineering Trucks Attachments Co., Ltd.

We reserve the right to amend this product manual.

No further notice will be given if any changes are made.

# PRODUCT CATALOG

Anqing liandong Engineering Trucks Attachments Co., Ltd.

- ◆ SIDESHIFTERS
- ◆ FORK POSITIONERS
- ◆ PUSH/PULLS
- ◆ PAPER ROLL CLAMPS
- ◆ ROTATORS
- ◆ CLAMPS
- ◆ MULTIPLE LOADS HANDLERS
- ◆ SPECIALTY PRODUCTS



## 简介

Anqing liandong Engineering Trucks Attachments Co., Ltd. is a state-owned large-scale enterprise--owned subsidiary of Anhui Forklift Group Co., Ltd. It is a specialized and large-scale company of forklifts with R&D, manufacturing, sales and service. At present, there are four types of products, nearly 1,800 series, key components and components are independently developed and manufactured. Many products have independent intellectual property rights and have obtained 61 national patents. The company has been rated as "High-tech Enterprise of Anhui Province", "Innovative Pilot Enterprise of Anhui Province" and "Provincial Enterprise Technology Center". Liandong attachments is a good helper for forklifts. Its products are widely used in papermaking, warehousing, tobacco, port, chemical, construction, smelting and other industries. It is a high-efficiency intelligent handling equipment for mechanized loading, unloading, stacking and short-distance handling.

The company has high-efficiency digital intelligent equipment such as CNC cutting machine, welding robot, machining center, CNC lathe, shot blasting machine, washing machine and painting line. It has advanced physical and chemical laboratories and perfect product testing and testing facilities. At present, the company has an annual production capacity of 80,000 side shifters and 8,000 sets of various types of clips. It has passed ISO9001, ISO14001, OHSAS18001 three-system certification and ISO3834-2 international welding quality system certification. The company has been recognized as a national safety production standardization secondary enterprise.

Liandong attachments has actively carried out related work on brand building. 77 products have passed the CE safety certification of the European Union. The company's trademark "LDSJ" has been successfully registered in 12 domestic trademarks. The international trademarks have been successfully registered in Germany, Britain, the United States and Korea. . Successfully declared the famous trademark of Anhui Province in 2017, approved by the Madrid trademark, covering India, the Russian Federation, Australia, Vietnam, the Philippines and other five countries; through the Anhui Province AAA standardization good behavior creation work and confirmed by audit.

On March 17, 2016, Anqing liandong Engineering Trucks Attachments Co., Ltd. was successfully listed on the New Third Board (stock short name: Liandong attachments; stock code: 835635).

The company's strategic goal is to take technological innovation as the guide, improve the overall technical level of the enterprise, and become an innovative leading enterprise in the technological development of the industry; with the forklift attachment as the center, expand into the field of engineering machinery attachments, become mechanized loading and unloading, stacking and System service providers for short-distances logistics handling equipment and handling solutions; using information technology as a means, using two-in-one integration as a carrier to enhance the company's intelligent manufacturing level and achieve sustainable, healthy and stable development of the company.

### Product Description

The models listed in this product catalog are only partial products of Liandong Attachments. We will provide proper solutions according to user's special requirement. Please contact our sales department for more information.

### Forklift matching requirements

Please note the flow and pressure requirements for each type of attachment. Working pressure of attachment should not exceed its maximum value. Please follow the recommended flow rate value to set the oil supply of the forklift's additional oil line, so as to achieve the best working performance. If a special performance parameter is required, such as various pressure settings, please increase other auxiliary devices.

### Attachment joint situation

Standard configuration of oil port connector is national standard face seal type (dimension of screw thread: M18 x 1.5). If a special connection form is required, please contact our technology department.

### Bearing capacity of attachment

The bearing capacity of attachment is only one parameter to the performance of its structure. The actual comprehensive bearing capacity depends on the carrying goods, working conditions and bearing capacity of forklift. Accurate comprehensive bearing capacity of forklift/attachment can be obtained from the forklift host factory. The values calculated according to the forklift/attachment comprehensive bearing capacity formula listed on page 3 in this catalog are estimated values, only for reference.

### Attachment mounting class

Attachment mounting class means the installation hook type at the back of product. All standard products have these hooks. The carriage of forklift shall comply with international standard, to mount and connect properly. ng capacity formula listed on page 3 in this catalog are estimated values, only for reference.

Mounting class meanings as the following chart:

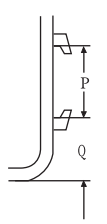

Mounting class	Lift Truck Capacity ( Kg )	Load Center ( mm )	P ( mm )	Q ( mm )
I	-999	500	331	76
II	1000-2500	500	407	76
III	2501-4999	500	508	76
IV	5000-8000	600	635	127
V	8001-10999	600	728	127

Note: in case of installing the attachment on a non-standard carriage, please consult the sales department of Anqing Liandong Engineering Trucks Attachments Co.,Ltd, in advance.

### Length of clamp arm or fork

The clamp arm or fork length listed in this product catalog is the effective length for actual operation of clamp arm or fork, which means the horizontal distance from the end face to the tip of arm or tip of fork under loading.

### Quality assurance policy

Anqing Liandong Engineering Trucks Attachments Co.,Ltd, shall be in accordance with the quality assurance policy, take a warranty period of 12 months / 2000 hours (whichever occurs first) for its new forklift attachments from the date of delivering to the first carrier. For details see "Quality Assurance Policy"(page 4).

### Return policy

For detailed information, please refer to pageV in this catalog.

Bearing capacity is an important factor that must be considered in the selection process of forklift and attachment type. The comprehensive bearing capacity of forklift/attachment will fall after installing attachments on the counter balanced forklift, due to the following two factors:

- ①the load torque of forklift is partially offset by the torque produced by attachment weight.
- ②the rear frame structure thickness of attachment forms a part of the actual load torque. The following formulas will help calculate the bearing capacity, i.e. the load weight limit, only for reference.

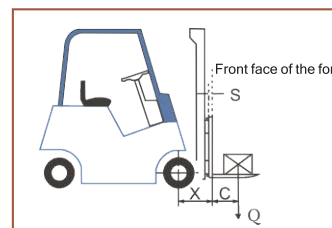

### CALCULATION PARAMETERS OF THE FORKLIFT

Q: rated bearing capacity of the forklift (Kg)  
 (note: the rated bearing capacity of the forklift is related to its maximum lifting height)  
 X: horizontal distance from the front wheel center to the front end face of forklift (mm)  
 C: horizontal distance from the front end of fork to the load center (mm)  
 S: fork thickness (mm)

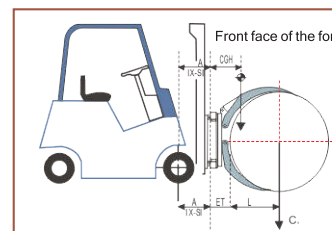

### CALCULATION PARAMETERS OF ATTACHMENT

M: weight of the attachment (Kg)  
 A: horizontal distance from the front wheel center to the front end face of fork (mm) A=X-S  
 CGH: horizontal distance from the front end face of fork frame to the weight center of attachment (mm)  
 ET: horizontal distance from the front end face of fork frame to the rear end face of load (mm)  
 L: horizontal distance from the rear end face of load to the load center (mm)

### COMPREHENSIVE BEARING CAPACITY:

$$C_N = \frac{Q(X+C) - M(A+CGH)}{A+ET+L}$$

FOR EXAMPLE, ASSUMING THAT:

Q=3000Kg X=498mm C=500mm S=45mm M=560Kg A=453mm CGH=280mm  
 ET=220mm L=500mm

$$C_N = \frac{3000 \times (498+500) - 560 \times (453+280)}{453+220+500} = 2202\text{Kg}$$

Take the minimum among the rated forklift bearing capacity, attachment bearing capacity and calculated comprehensive bearing capacity as the integral actual bearing capacity of forklift/attachment. Weight of carried goods shall not exceed this value.

★You can obtain the accurate comprehensive bearing capacity of forklift/attachment from the forklift host factory.



## Quality Assurance Policy

Thank you for choosing the attachment product of Liandong. In order to fully protect your rights, please read this quality assurance policy carefully.

**Anqing Liandong Engineering Trucks Attachments Co.,Ltd:** ensure its products meet the requirements for performance parameters listed in the effective purchases and sales contract, quotation, and product catalog provided by Liandong company.

**Anqing Liandong Engineering Trucks Attachments Co.,Ltd:** the company has two classes of product, brand new product and repaired product. Including attachments and repair parts.

### 1.Brand new product: warranty period as follows:

- (1) 12 months from Anqing Liandong?Engineering?Trucks?Attachments?Co.fLtd delivering to the first carrier;
  - (2) Use the attachment for 2000 hours.
- Whichever occurs first

### 2.Repaired product:

the warranty period is 6 months from Anqing Liandong Engineering Trucks Attachments Co.,Ltd delivering the product.

**In this policy, 4,Quality Assurance" means:** Anqing Liandong Engineering Trucks Attachments Co.,Ltd will repair or replace any part with defects in material or workmanship confirmed by its authorized officer or its sales staff after checking.

### Buyers and end users shall:

- 1.In order to ensure the company's work can be implemented smoothly, buyers and end users must operate in strict accordance with the requirements of relevant Liandong installation instructions, test specifications, operating instructions and maintenance manuals while installing, commissioning, using and maintaining the products of Liandong.
- 2.Buyers and end users must obtain authorization from Liandong before repairing the products purchased from Liandong, but no product part can be removed or replaced.
- 3.Without authorization from Liandong Company, any repair or alteration of its attachment product, use of parts not provided by Liandong, or violation of relevant provisions in Liandong1 s installation instructions, test specifications, operation instructions and maintenance manual will result in losing the right of quality assurance policy.

### Precautions:

- 1 .For damage or abnormal conditions to the product caused by special operations beyond the applicable working condition of the product, Anqing Liandong Engineering Trucks Attachments Co.,Ltd won't take the responsibility of repair.
- 2.When the buyer or end user has owned or has not yet owned but already started using the company's products, Anqing Liandong Engineering Trucks Attachments Co.,Ltd won't take the responsibility for loss of the products or person or property loss caused during the use of the product (including indirect loss or damage).
- 3.Product abrasion and consumption during normal use, abnormal use without following the company1 s operation introduction, as well as normal or regular maintenance work do not enjoy the quality assurance policy.

4.Circumstances beyond this quality policy and product-related terms on the purchases and sales contract of Anqing Liandong Engineering Trucks Attachments Co.,Ltd, do not enjoy the quality assurance policy.

### Important notice:

f the end user need to learn more about the company's products or installation and repair matters, please consult the forklift host factory that sold this product or its dealer first. Liandong Company is also very happy to answer any of your questions in this regard. Please contact: Technology Department/ Sales Department of Anqing Liandong Engineering Trucks Attachments Co.,Ltd, tel: 0556-5345329/5228123.

This quality assurance policy takes effect from Jan. 1, 2008. It will be effective till the introduction of new quality assurance policy. Anqing Liandong Engineering Trucks Attachments Co.;Ltd reserves the right to amend this policy according to market and technology developments, without one by one notice.



## Return Policy

Forklift attachments are installed on the forklift of a particular tonnage and mounting class, which are specialized mechanical equipment for the appropriate shape and weight of goods.

Therefore, before signing the attachment sales contract, sales manager of Anqing Liandong?Engineering?Trucks Attachments Co.,Ltd, and sales managers of the forklift host factory and its dealer must communicate adequately on how to make the proposed attachment meet the user\* s requirements, and reach an agreement.

### Return applications caused by non-attachment quality problems are suitable to the following policies:

In case of return of universal standard brand new attachments (unused), the forklift host factory or sales company sold this product shall contact the sales manager of Anqing Liandong?Engineering?Trucks Attachments Co.,Ltd to get return permission.

For all applications, the "Return Permission" must be returned with the goods. The returns party shall bear the product transport fee, packaging costs (round trip), detection and identification fee of the product, related service fee, management fee and loss of spare parts (in real terms). If damaged during shipping, the returns party shall also bear the repairing cost (in real terms).

### In the following conditions, return will be refused:

- ☞ Used product (no quality issues)
- ☞ Modified product (without permission of the company)
- ☞ Custom designed product
- ☞ Product exceeding 60 days from the delivery date of the company
- ☞ Not returnable products specified by the contract

1	Sideshifters	1-4
2	Fork Positioners	5-6
3	Paper Roll Clamps	7-10
4	Rotators	11-13
5	Tyre Clamps	14
6	Material Senders	15
7	Bale Clamps	16-20
8	Pulp Bale Clamps	21
9	Multi-purpose Clamps	22-23
10	Carton Clamps	24
11	Tobacco Carton Clamps	25-26
12	Fork Clamps	27
13	Block Clamps	28-30
14	Bar Arm Clamps	31
15	Drum Clamps	32-34
16	Turnloads	35
17	Foam Rubber Clamps	36
18	Waste Paper Clamps	37
19	Single double Pallets Handlers	38
20	Sideshifting Tyre Clamp	39
21	Push/Pull	40-43
22	Inverta Push Clamps	44
23	Launch Stabilizer	45
24	Load Extender	46
25	Cage Block Clamps	47
26	Economic Type Dump	48
27	Single Cylinder Tilting Frame	49
28	Double Cylinder Tilting Frame	50
29	Load Stabilizers	51
30	Carpet Boom	52
31	Sanitation Fork	53
32	Olecranon Drum Clamps	54
33	Log Holder	55-56
34	Hinged Broke Handler	57
35	Glass Handler	58
36	Lifting Arm	59

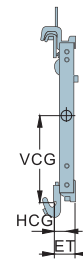
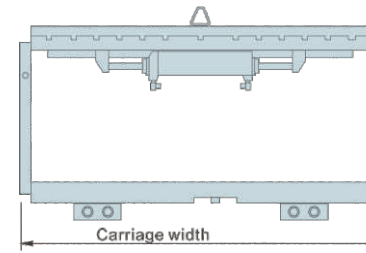

Capacity@ Load Center	Catalog Order No.	Mounting Class	Carriage Width	Minimum Truck Carriage Width	Weight	Effective Thickness	Vertical Center of Gravity	Horizontal Center of Gravity	Available Forklift
(Kg@mm)			(mm)	(mm)	(kg)	ET (mm)	VCG (mm)	HCG (mm)	(t)
1800@500	LC15	II	970	900	55	63	230	28	1-1.8t
2500@500	LC20	II	1040	970	58	63	230	28	2-2.5t
3000@500	LC30	III	1100	1000	74	68	300	29	3-3.5t
4500@500	LC45	III	1380	1200	180	79	284	39	4.5t

- Note: 1. Please obtain the actual comprehensive bearing capacity of forklift/attachment from the forklift factory.  
 2. The forklift needs to add a group of additional oil lines.  
 3. The total amount of side shift is: 200 (±100) mm.

Model	Pressure Value Bar		Flow Value L/min		
	Min.	Max.	Min.	Recommend	Max.
LC	140	210	4	8	11



### Configuration of Key Parts of Truck Attachments

1. Hydraulic system: The piston rod adopts integral type, the structure is simple, easy to process and repair; the seals all adopt well-known brand series products, the quality is reliable; the design has throttle pieces, which can adjust the side shift speed.
2. Performance: The slider is made of modified engineering plastic wear-resistant material and has a long service life.

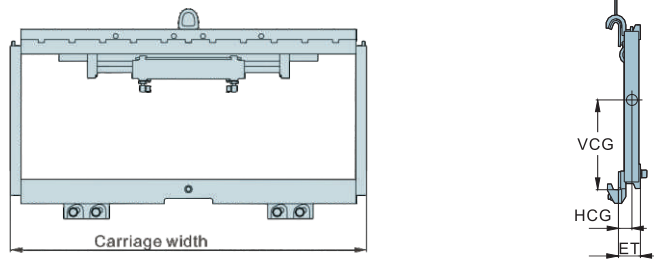

Capacity@ Load Center	Catalog Order No.	Mounting Class	Total Side shift	Carriage Width	Minimum Truck Carriage width	Weight	Effective Thickness	Vertical Center of Gravity	Horizontal Center of Gravity	Available Forklift
(Kg@mm)			(mm)	(mm)	(mm)	(kg)	ET (mm)	VCG (mm)	HCG (mm)	(t)
1800@500	<b>GC15</b>	II	±100	970	895	51	63	220	25	1-1.8t
2500@500	<b>GC20</b>	II	±100	1040	940	55	63	220	25	2-2.5t
3000@500	<b>GC30</b>	III	±100	1100	970	72	68	295	28	3t
3000@500	<b>GC30A</b>	III	±100	1250	1100	77	68	295	28	3t
3000@500	<b>GC30B</b>	III	±100	1300	1100	78	68	295	28	3t
3500@500	<b>GC35</b>	III	±100	1100	970	85	73	295	32	3.5t
3500@500	<b>GC35A</b>	III	±100	1500	1300	124	73	295	32	3.5t
3500@500	<b>GC35B</b>	III	±100	1600	1300	132	73	295	32	3.5t
3500@500	<b>GC35C</b>	III	±100	1700	1400	139	73	295	32	3.5t
4500@500	<b>GC45</b>	III	±100	1380	1180	115	73	295	32	4-4.5t
4500@500	<b>GC45A</b>	III	±100	1200	1000	106	73	295	32	4-4.5t
4500@500	<b>GC45B</b>	III	±100	1350	1200	114	73	295	32	4-4.5t
4500@500	<b>GC45E</b>	III	±150	1380	1300	150	78	227	46	4-4.5t
6800@610	<b>GC70</b>	IV	±150	1845	1525	330	84	380	43	5-7t
6800@610	<b>GC70A</b>	IV	±150	2430	1735	406	84	387	47	5-7t
6800@610	<b>GC70B</b>	IV	±150	1532	1470	286	84	380	42	5-7t

Note: 1. Please obtain the actual comprehensive bearing capacity of forklift/attachment from the forklift factory.  
 2. The forklift needs to add a group of additional oil lines.  
 3. According to demand, special width of sideshifter can be provided.



Model	Pressure Value Bar		Flow Value L/min		
	Min.	Max.	Min.	Recommend	Max.
<b>GC15-45</b>	140	210	4	8	11
<b>GC70</b>	140	210	4	23	45

### Configuration of Key Parts of Truck Attachments

1. Hydraulic system: the piston rod adopts integral structure, cylinder head and cylinder retainer are connected by clamp spring, which has high reliability; all seals adopt well-known brand products with reliable quality; there are throttling pieces to adjust the sideshifting speed.  
 2. Structural part: it uses forgings on the lower hook of sideshifter, which is easy for assembly and adjustment, with novel structure and reliable quality.  
 3. Mechanical performance: the oil cylinder of sideshifter uses a cushioning device, which can automatically reduce the sideshifting speed when reaching the end, to effectively protect the goods; the lower hook on the sideshifter is fixed with lock nuts, which is safe and reliable.

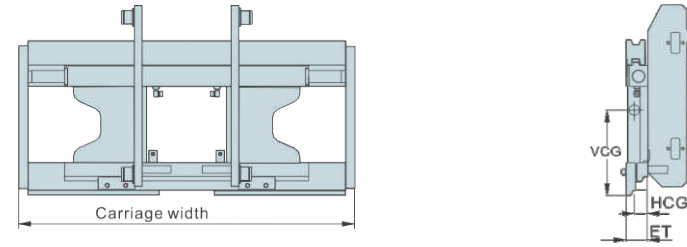

Capacity@ Load Center	Catalog Order No.	Mounting Class	Carriage Width	Weight	Effective Thickness	Available Forklift
(Kg@mm)			(mm)	(kg)	ET (mm)	(t)
1800@500	<b>ZC15</b>	II	970	115	70	1-1.8t
2500@500	<b>ZC20</b>	II	1040	134	70	2-2.5t
3000@500	<b>ZC30</b>	III	1100	167	70	3t
3500@500	<b>ZC35</b>	III	1100	220	85	3.5t

Note: 1. Since different model of fork frame has different matching condition, and the riser and roller shaft are associated with this sideshifter, please provide the forklift carriage drawing when ordering.  
 2. Delivery does not include the roller assembly.  
 3. The forklift needs to add a group of additional oil lines.  
 4. Total sideshifting length: 200 (±100) mm.

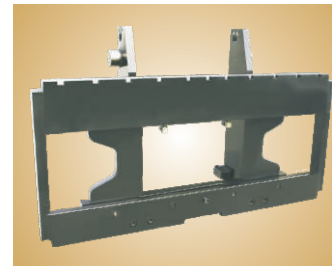

Model	Pressure Value Bar		Flow Value L/min		
	Min.	Max.	Min.	Recommend	Max.
<b>ZC</b>	160	210	4	8	11

### Configuration of Key Parts of Truck Attachments

1. Hydraulic system: the sideshift oil cylinder uses plunger type cylinder, which is simple in structure and convenient for repairing; all seals adopt well-known brand products with stable and reliable quality.  
 2. Structural part: upper and lower beams use high-strength plates. There are also baffles outside the oil cylinder to protect the piston rod from damage.  
 Mechanical performance: the oil cylinder is built in the upper beam, forming a compact structure to effectively improve the bearing capacity of sideshifters; buffered loops on the rod ends can reduce the impact to protect the goods; it also combines functions of the sideshifter and carriage, thereby reducing the front overhang of door frame, and greatly improves the vehicle's cost performance, bearing capacity and whole-machine reliability.

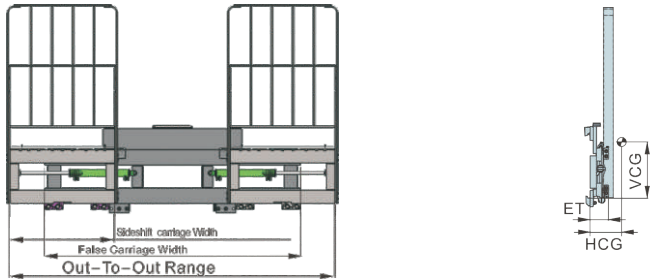

Capacity@ Load Center (Kg@mm)	Catalog Order No.	Truck Mounting Class	Hinged Fork Mounting Class	Out-To-Out Range (mm)	The single side shift (mm)	Sideshift Carriage Width (mm)	Carriage Width (mm)	Maximum Pallet Spread (mm)	Weight (kg)	Effective Thickness ET (mm)	Horizontal Center of Gravity HCG (mm)	Available Forklift (t)
3000@610	SC30D-B1	III	II	1760-2450	345	790	1930	800	341	119	53	3-4.5t
3000@610	SC30D-B2	III	II	1448-2052	300	700	1620	604	328	143	90	3-4.5t

- Notes: 1. Please gain the actual overall carrying capacity of forklift trucks/attachments from the forklift truck manufacturers.  
 2. Forklift truck needs to add two groups of additional oil lines so as to match the attachments.  
 3. The minimum truck carriage width shall be 955mm.  
 4. Optional fork bracket without fork.



Model	Pressure Value Bar		Flow Value L/min	
	Max.	Min.	Recommend	Max.
SC* *D	210	4	8	11

### Configuration of Key Parts of Truck Attachments

- Hydraulic system: all the seals adopt imported products and the high-pressure rubber hoses adopt cone sealed high-performance imported rubber hoses.
- Structural part: the truck carriages are welded by high-performance alloy steel plates.
- Mechanical performance: two sideshift carriages can act respectively (separate, close, left shift and right shift) with good view.
- Applicable scope: if applicable on handling various box and bulk cargoes, by making the fork truck move two pallets of goods respectively and making them close or separate, so as to improve the handling efficiency significantly.

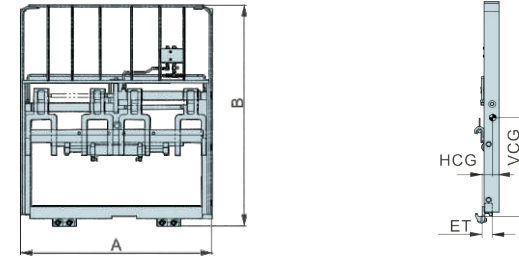

Capacity@ Load Center (Kg@mm)	Catalog Order No.	Mounting Class	Opening Range (mm)	Total Side shift (mm)	Fork Pocket Width (mm)	Minimum Truck Carriage Width (mm)	Overall Width A (mm)	Overall Height B (mm)	Weight (kg)	Effective Thickness ET (mm)	Horizontal Center of Gravity HCG (mm)	Available Forklift (t)
1800@500	TC18G-A1	II	100-900	100	895	1018	1245	135	63	50	1-1.8t	
2500@500	TC25G-A1	II	100-970	100	895	1088	1245	148	63	50	2-2.5t	
2500@500	TC25G-A2	II	100-970	122	895	1088	1245	148	63	50	2-2.5t	
3000@500	TC30G-B1	III	100-1125	125	930	1248	1336	186	68	50	3-3.5t	
3000@500	TC30G-B2	III	100-1025	125	930	1148	1336	178	68	50	3-3.5t	
3500@500	TC35G-B1	III	100-1025	150	930	1148	1336	181	68	50	3-3.5t	
4500@500	TC45G-B1	III	100-1300	150	1080	1428	1343	256	73	50	4-4.5t	
6800@600	TC70G-C1	IV	120-1750	150	1420	1905	1452	553	75	57	5-7t	
1800@500	TY18G-A1	II	100-900	±100	100	895	1018	1245	139	62	50	1-1.8t
2500@500	TY25G-A1	II	100-970	±100	100	940	1088	1245	152	62	50	2-2.5t
2500@500	TY25G-A3	II	100-1230	±100	100	1090	1348	1245	178	62	50	2-2.5t
2500@500	TY25G-A5	II	100-970	±100	122	940	1088	1245	152	62	50	2-2.5t
3000@500	TY30G-B1	III	100-1025	±100	125	970	1148	1336	182	68	50	3-3.5t
3000@500	TY30G-B2	III	100-1125	±100	125	1070	1248	1336	190	68	50	3-3.5t
3000@500	TY30G-B4	III	100-1440	±100	125	1400	1568	1336	215	68	50	3-3.5t
3500@500	TY35G-B1	III	100-1025	±100	150	970	1148	1336	185	68	50	3-3.5t
4500@500	TY45G-B1	III	100-1300	±100	150	1180	1428	1345	260	73	50	4-4.5t
4500@500	TY45G-B3	III	100-1620	±100	150	1400	1748	1345	280	73	56	4-4.5t
4500@500	TY45G-B4	III	100-1810	±100	150	1600	1968	1345	398	78	57	4-4.5t
6800@600	TY70G-C1	IV	120-1750	±150	150	1525	1905	1418	550	84	57	5-7t
6800@600	TY70G-C2	IV	115-1850	±150	150	1525	2000	1300	555	84	57	5-7t

- Notes: 1. Please gain the actual overall carrying capacity of forklift trucks/attachments from the forklift truck manufacturers.  
 2. Opening range: the minimum is the inside distance between two forks while they are closing, and the maximum is the outside distance between two forks while they are opening.  
 3. In the Catalog Order No. \*TC\* refers to fork positioners, while \*TY\* refers to sideshift fork positioners.  
 4. Separate pitch adjustment at the end of the original product model of the TC series plus "-01".  
 5. It is recommended that the length of the fork does not exceed 1520mm.

Model	Pressure Value Bar		Flow Value L/min	
	Max.	Min.	Recommend	Max.
TC(Y) **G	180	11	15	19



### Configuration of Key Parts of Truck Attachments

- Hydraulic system: the control valves adopt foreign originally imported hydraulic products; and the high-pressure rubber hoses adopt cone sealed high-performance imported rubber hoses.
- Structural part: it can match the standard fork bracket, and the shift forks adopt integral alloy steel castings, and it has beautiful appearance and reliable performance.
- Mechanical performance: it uses balance valve to ensure that two forks can run synchronously, and the forks are controlled by double oil cylinder with good stability; and uses the standard forks for forklift trucks, which has excellent versatility and convenient installation.

### Users can choose to include the sideshift function or not Configuration as follows:

- The forks position independently, without sideshift function, and need to add two groups of additional oil lines (without synchronous valves).
- The forks position synchronously, with sideshift function, and need to add two groups of additional oil lines (with synchronous valves).
- The forks position synchronously, without sideshift function, and need to add a group of additional oil lines (with synchronous valves).

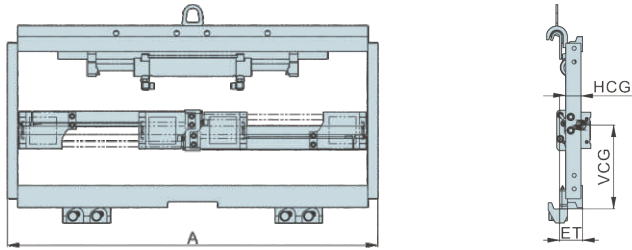

Capacity@ Load Center (Kg@mm)	Catalog Order No.	Roll Range (mm)	Minimum Truck Carriage Width (mm)	Overall Width (mm)	Fork pocket Width (mm)	Weight (kg)	Truck Mounting Class	Effective Thickness ET (mm)	Vertical Center of Gravity VCG (mm)	Horizontal Center of Gravity HCG (mm)	Available Forklift (t)
1800@500	<b>TY18G-A2</b>	28-860	895	970	100	72	II	68	218	31	1-1.8t
2500@500	<b>TY25G-A4</b>	28-930	940	1040	100/122	78	II	68	218	31	2-2.5t
3000@500	<b>TY30G-B3</b>	28-990	970	1100	125	90	III	68	275	31	3-4.5t

- Notes: 1. Please gain the actual overall carrying capacity of forklift trucks/attachments from the forklift truck manufacturers.  
 2. The forklift truck needs to add two groups of additional oil lines so as to match the attachments.  
 3. Opening range: the minimum is the inside distance between two forks while they are closing, and the maximum is the outside distance between two forks while they are opening.  
 4. Sideshifting amount of the fork positioner is  $\pm 100$ mm.  
 5. The model listed on this page only fits the basic portal frame. For more information about the models of portal frame, please contact the sales clerks.  
 6. It is recommended that the length of the fork does not exceed 1520mm.



Model	Pressure Value Bar		Flow Value L/min	
	Max.	Min.	Recommend	Max.
<b>TY**G</b>	140	4	8	11

### Configuration of Key Parts of Truck Attachments

1. Hydraulic system: the piston rod of the sideshift oil cylinder adopts the integral type, which is simple in structure and convenient for processing and repairing; the positioning oil cylinder has throttle valve to adjust the fork positioning speed, and the seals adopt well-known brand products with reliable quality.
2. Mechanical performance: the shift fork adopts fine steel castings, which is indestructible, and connected with supporting rod to reach compact structure, and light in weight to be convenient for fork installation, and the distance between forks while closing is smaller, respectively and making them close or separate, so as to improve the handling efficiency significantly.

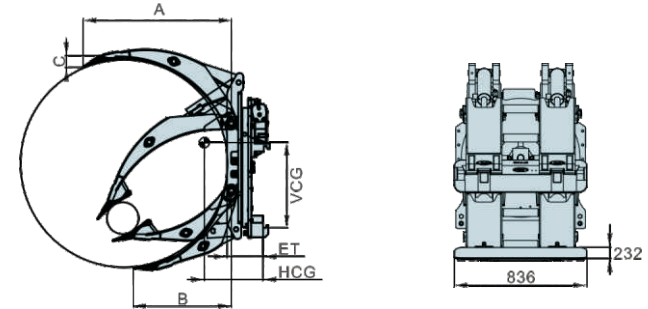

Capacity@ Load Center (Kg@mm)	Catalog Order No.	Catalog Order No.	Truck Mounting Class	Long Arm Length (mm)	Short Arm Length (mm)	Arm Height (mm)	Weight (kg)	Effective Thickness ET (mm)	Vertical Center of Gravity VCG (mm)	Horizontal Center of Gravity HCG (mm)	Available Forklift (t)
2000@1400	<b>ZJ20L-B1</b>	440-1400	III	991	659	50	632	225	432	302	3-4.5t
2000@1300	<b>ZJ20L-B2</b>	200-1300	III	785	487	50	642	226	430	293	3-4.5t
2000@1300	<b>ZJ20L-B3</b>	630-1340	III	875	655	50	639	226	430	293	3-4.5t
2000@1400	<b>ZJ20L-B14</b>	200-1400	III	991	659	50	635	225	432	307	3-4.5t

- Notes: 1. Please gain the actual overall carrying capacity of forklift trucks/attachments from the forklift truck manufacturers.  
 2. Forklift truck needs to add two groups of additional oil lines.  
 3. It can provide non-standard clamping plates suitable for different paper roll clamping requirements according to the needs of users.  
 4. If the model mantissa is odd, the short arm is fixed, and the even number is short.

Model	Pressure Value Bar		Flow Value L/min					
	Min.	Max.	Rotating action		Clamping action			
			Min. Recommend	Max.	Min. Recommend	Max.		
<b>ZJ20L</b>	35	160	19	38	57	19	38	57

Model	Rotating speed	Torque
<b>ZJ20L</b>	4.5r/min@57L/min	9000N.m@160Bar



### Configuration of Key Parts of Truck Attachments

1. Hydraulic system: it adopts two-way hydraulic locks for rotating oil lines so as to realize two-way hydraulic self-locking and ensure the safety at work, and adds hydraulic control check valve for each oil cylinder to realize holding pressure for a long time. All the motors, valves and seals adopt originally imported products; and the high-pressure rubber hoses adopt cone sealed high-performance rubber hoses.
2. Structural part: it adopts large-modulus slewing bearing, which has stronger bearing capacity; turbine and worm adopts involute gears, so as to not only increase the efficiency and decrease the heat loss, but also realize the self-locking function.
3. Mechanical performance: it can realize the 360° rotation, and change the thickness of the clamp arm, both ends of the clamp arm are welded by V-shape castings so as to increase the capacity of resisting the load impact.
4. Applicable scope: it's applied to the papermaking, packaging, printing and other industries, by conducting high-efficiency and non-damage handling and stacking operation for various paper rolls.
5. We can provide non-standard clamps to suit different paper rolls upon request. Please contact the sales department for more information.



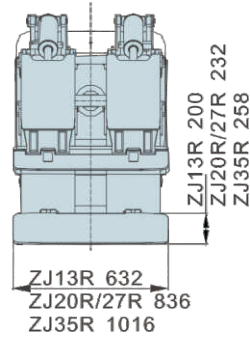
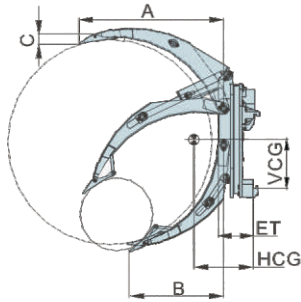

- Notes: 1. Please gain the actual overall carrying capacity of forklift trucks/attachments from the forklift truck manufacturers.  
 2. Forklift truck needs to add two groups of additional oil lines.  
 3. It can provide non-standard clamping plates suitable for different paper roll clamping requirements according to the needs of users.  
 4. If the model mantissa is odd, the short arm is fixed, and the even number is short.

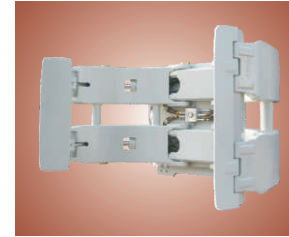

Model	Rotating speed	Torque
ZJ12/13R	7.5r/min@38L/min	4200N.m@160Bar
ZJ20R/27R	5.2r/min@57L/min	9000N.m@160Bar
ZJ35R	4.1r/min@76L/min	11000N.m@160Bar

Model	Pressure Value Bar		Flow Value L/min					
	Min.	Max.	Rotating action		Clamping action			
			Min.	Recommend	Max.	Min.	Recommend	Max.
ZJ12/13R	35	160	19	26	38	19	26	38
ZJ20R/27R	35	160	19	38	57	19	38	57
ZJ35R	35	160	38	57	76	38	57	76

### Configuration of Key Parts of Truck Attachments

1. Hydraulic system: it adopts two-way hydraulic locks for rotating oil lines so as to realize two-way hydraulic self-locking and ensure the safety at work, and adds hydraulic control check valve for each oil cylinder to realize holding pressure for a long time. All the motors, valves and seals adopt originally imported products; and the high-pressure rubber hoses adopt cone sealed high-performance rubber hoses.
2. Structural part: it adopts large-modulus slewing bearing, which has stronger bearing capacity; turbine and worm adopts involute gears, so as to not only increase the efficiency and decrease the heat loss, but also realize the self-locking function.
3. Mechanical performance: it can realize the 360° rotation, and the clamp arm body is welded by high-strength alloy structural steels, so as to ensure the strength of clamp arm at work and avoid the damage of impact load.
4. Applicable scope: it's applied to the papermaking, packaging, printing and other industries, by conducting high-efficiency and non-damage handling and stacking operation for various paper rolls.
5. We can provide non-standard clamps to suit different paper rolls upon request. Please contact the sales department for more information.

Capacity@ Max. Diameter	Catalog Order No.	Opening Range	Mounting Class	Long Arm Length	Short Arm Length	Arm Thickness	Weight	Effective Thickness	Vertical Center of Gravity	Horizontal Center of Gravity	Available Forklift
(Kg@mm)	(mm)	(mm)		A (mm)	B (mm)	C (mm)	(kg)	ET (mm)	VCG (mm)	HCG (mm)	(t)
1000@1600	ZJ10R-A1	560-1600	II	995	675	45	420	135	330	290	1.2-5t
1100@1500	ZJ11R-A1	450-1500	II	890	640	45	400	135	330	300	1.2-5t
1200@1300	ZJ12R-A1	410-1300	III	860	570	45	376	135	340	255	1.2-5t
1200@1300	ZJ12R-B1	410-1300	III	860	570	45	380	135	340	255	3.4-5t
1300@1150	ZJ13R-A1	330-1150	II	745	535	45	385	135	335	250	1.2-5t
1300@1150	ZJ13R-B1	330-1150	III	745	535	50	385	135	335	250	3.4-5t
2000@1400	ZJ20R-A1	500-1400	II	980	665	50	710	240	340	405	2.2-5t
2000@1340	ZJ20R-A2	220-1340	II	875	655	50	700	240	340	325	2.2-5t
2000@1340	ZJ20R-A3	630-1340	II	875	655	50	680	240	340	325	2.2-5t
2000@1600	ZJ20R-A4	300-1600	II	1075	740	50	860	240	350	385	2.2-5t
2000@1600	ZJ20R-A5	600-1600	II	1075	740	50	850	240	350	385	2.2-5t
1700@1830	ZJ20R-A6	380-1830	II	1225	815	50	915	240	405	373	2.2-5t
1700@1830	ZJ20R-A7	680-1830	II	1225	815	50	895	240	405	373	2.2-5t
2000@1520	ZJ20R-A8	250-1520	II	1010	685	50	750	240	350	350	2.2-5t
2000@1520	ZJ20R-A9	630-1520	II	1010	685	50	740	240	350	350	2.2-5t
2000@1400	ZJ20R-B1	500-1400	III	980	665	50	710	240	340	405	3.4-5t
2000@1340	ZJ20R-B2	220-1340	III	875	655	50	700	240	340	325	3.4-5t
2000@1340	ZJ20R-B3	630-1340	III	875	655	50	680	240	340	325	3.4-5t
2000@1600	ZJ20R-B4	300-1600	III	1075	740	50	810	240	350	385	3.4-5t
2000@1600	ZJ20R-B5	600-1600	III	1075	740	50	800	240	350	385	3.4-5t
1700@1830	ZJ20R-B6	380-1830	III	1225	815	50	860	240	405	373	3.4-5t
1700@1830	ZJ20R-B7	680-1830	III	1225	815	50	850	240	405	373	3.4-5t
2000@1520	ZJ20R-B8	250-1520	III	1010	685	50	750	240	350	350	3.4-5t
2000@1520	ZJ20R-B9	630-1520	III	1010	685	50	740	240	350	350	3.4-5t
2700@1400	ZJ27R-B1	500-1400	III	980	665	50	814	213	460	290	3.4-5t
2700@1340	ZJ27R-B2	220-1340	III	875	655	50	830	213	490	290	3.4-5t
2700@1340	ZJ27R-B3	630-1340	III	875	655	50	795	213	502	276	3.4-5t
2700@1600	ZJ27R-B4	300-1600	III	1075	740	50	910	213	530	330	3.4-5t
2700@1600	ZJ27R-B5	600-1600	III	1075	740	50	878	213	516	314	3.4-5t
2300@1830	ZJ27R-B6	380-1830	III	1225	815	50	1110	213	550	355	3.4-5t
2300@1830	ZJ27R-B7	680-1830	III	1225	815	50	1070	213	545	347	3.4-5t
2700@1520	ZJ27R-B8	250-1520	III	1010	690	50	855	213	510	300	3.4-5t
2700@1520	ZJ27R-B9	630-1520	III	1010	690	50	820	213	500	310	3.4-5t
2300@1830	ZJ27R-C7	680-1830	IV	1225	815	50	1085	213	545	375	5-7t
3500@1520	ZJ35R-B1	610-1520	III	1025	745	65	1215	229	560	335	3.4-5t
3500@1520	ZJ35R-B2	250-1520	III	1025	745	65	1235	229	570	340	3.4-5t
3500@1520	ZJ35R-C1	610-1520	IV	1025	745	65	1215	229	560	335	5-7t
3500@1520	ZJ35R-C2	250-1520	IV	1025	745	65	1235	229	570	340	5-7t

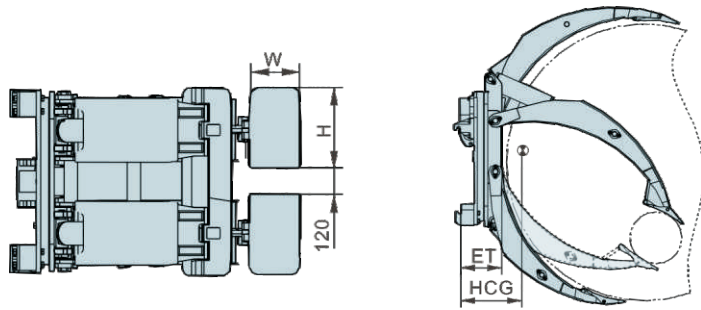

Capacity@ Max Diameter (Kg@mm)	Catalog Order No.	Mounting Class	Roll Size H×W (mm)	Weight (kg)	Effective Thickness ET (mm)	Horizontal Center of Gravity HCG (mm)	Available Forklift (t)
2000@1340	ZJ20A-B3	III	2×(358×232)	680	240	325	3-4.5t
2000@1600	ZJ20A-B4	III	2×(358×232)	810	240	340	3-4.5t
2700@1520	ZJ27A-B8	III	2×(358×232)	855	213	300	3-4.5t

- Notes: 1. Please gain the actual overall carrying capacity of forklift trucks/attachments from the forklift truck manufacturers.  
 2. Forklift truck needs to add two groups of additional oil lines.  
 3. It can provide non-standard clamping plates suitable for different paper roll clamping requirements according to the needs of users.

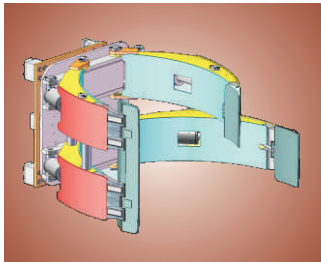

Model	Pressure Value Bar			Flow Value L/min		
	Min.	Max.	Rotating action Min. Recommend	Max.	Clamping action Min. Recommend	Max.
ZJ**A	35	160	19	38	57	19 38 57

Model	Rotating speed		Torque
	Min.	Max.	
ZJ**A	5.2r/min@57L/min		9000N.m@160Bar

### Configuration of Key Parts of Truck Attachments

- Hydraulic system: it adopts two-way hydraulic locks for rotating oil lines so as to realize two-way hydraulic self-locking and ensure the safety at work, and adds hydraulic control check valve for each oil cylinder to realize holding pressure for a long time. All the motors, valves and seals adopt originally imported products; and the high-pressure rubber hoses adopt cone sealed high-performance rubber hoses.
- Structural part: it adopts large-modulus slewing bearing, which has stronger bearing capacity; turbine and worm adopts involute gears, so as to not only increase the efficiency and decrease the heat loss, but also realize the self-locking function.
- Mechanical performance: both parts of the long arm can act respectively so as to realize clamping two paper rolls with different diameters at one time; its uniqueness lies in that while clamping a single paper roll, it only needs the corresponding long arm to clamp while the other one need not to do so, so as to increase the operating efficiency.
- Applicable scope: it's applied to the papermaking, packaging, printing and other industries, by conducting high-efficiency and non-damage handling and stacking operation for various paper rolls.

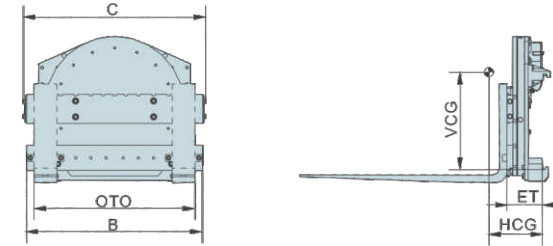

Suitable for casting industry

Capacity@ Load Center (Kg@mm)	Catalog Order No.	Overall Width C (mm)	Carriage Width B (mm)	Fork Pocket Width (mm)	Fork Max Spacing OTO (mm)	Mounting Class	Effective Thickness ET (mm)	Horizontal Center of Gravity HCG (mm)	Vertical Center Gravity VCG (mm)	Weight (kg)	Available Forklift (t)
1700@500	XZ17J-A1	840	815	100	712	II / II	128	68	260	195	1-2.5t
2200@500	XZ22J-A1	1180	1145	100/122	1040	II / II	189	125	310	293	1-2.5t
2200@500	XZ22J-A2	975	942	100/122	840	II / II	189	125	305	279	1-2.5t
2200@500	XZ22J-A3	840	815	100/122	713	II / II	189	125	305	335	1-2.5t
2200@500	XZ22J-B1	970	942	100/122	840	III / II	189	125	305	342	3-3.5t
3000@500	XZ30J-B5	1363	1343	125	1260	III / III	202	125	292	412	3-4.5t
3000@500	XZ30J-B1	1180	1145	125	1060	III / III	202	125	292	392	3-4.5t
3000@500	XZ30J-B2	1410	1375	125	1290	III / III	202	125	292	415	3-4.5t
3000@500	XZ30J-B3	1180	1145	125/100	1065	III / II	202	125	310	331	3-4.5t
3000@500	XZ30J-B4	1305	1270	125	1158	III / III	202	125	292	406	3-4.5t
3500@500	XZ35J-B1	1275	1240	125/150	1157	III / III	207	136	297	415	3-4.5t
3500@500	XZ35J-B2	1100	1065	125/150	925	III / III	207	135	280	398	3-4.5t
3500@500	XZ35J-B3	1633	1600	125/150	1500	III / III	207	138	295	476	3-4.5t
3500@500	XZ35J-B4	1275	1240	125/150	1135	III / III	207	135	322	406	3-4.5t
4500@500	XZ45J-B1	1600	1575	125/150	1445	III / III	220	139	322	610	3-4.5t
4500@500	XZ45J-B2	1341	1300	125/150	1200	III / III	220	135	280	572	3-4.5t
4500@500	XZ45J-B3	1585	1550	125/150	1470	III / IV	183	102	300	603	3-4.5t
4500@500	XZ45J-B4	1560	1525	125	1413	III / III	220	135	322	685	3-4.5t
5400@500	XZ60J-C1	1585	1550	150	1470	IV / IV	233	139	322	667	5-7t
5400@500	XZ60J-C2	1149	1115	150/125	985	IV / III	233	139	322	623	5-7t
5400@500	XZ60J-C3	1609	1575	150/125	1445	IV / III	233	139	322	679	5-7t
5400@500	XZ60J-C4	1735	1700	150	1612	IV / IV	233	139	322	689	5-7t
5400@500	XZ60J-C5	1815	1780	150	1700	IV / IV	233	139	322	735	5-7t

- Notes: 1. Please gain the actual overall carrying capacity of forklift truck attachments from the forklift truck manufacturers.  
 2. It can add forks according to the needs of users, and please pay attention to the bearing capacity of the fork itself.  
 3. Forklift truck needs to add a group of additional oil lines.  
 4. Forks equipped for rotators must be welded with middle hooks, and the whole machine of rotators out of factory shall be attached with middle hooks.  
 5. Rotators applicable for metallurgic industry can be provided with fitted forks. Please contact our sales department for more information.



Model	Pressure Value Bar		Flow Value L/min		
	Min.	Max.	Min.	Recommend	Max.
XZ17J	35	160	19	26	38
XZ22/30/35J	35	160	19	38	57
XZ45/60J	35	160	38	57	76
XZ100J	35	160	45	76	95
XZ17L	35	160	19	26	38
XZ22/30/35L	35	160	19	38	57
XZ60L	35	160	38	57	76

  

Model	Rotating speed	Torque
XZ17J	7.5r/min@38L/min	4200N.m@160Bar
XZ22/30/35J	5.2r/min@57L/min	9000N.m@160Bar
XZ45/60J	4.1r/min@57L/min	11000N.m@160Bar
XZ100J	3.3r/min@91L/min	24000N.m@160Bar
XZ17L	7.5r/min@38L/min	4200N.m@160Bar
XZ22/30/35L	6.5r/min@57L/min	10000N.m@160Bar
XZ60L	4.1r/min@57L/min	11000N.m@160Bar

### Configuration of Key Parts of Truck Attachments

1. Hydraulic system: it adopts two-way hydraulic locks so as to realize two-way hydraulic self-locking and ensure the safety at work; all the motors, valves and seals adopt originally imported products.
2. Structural part: it adopts large-modulus slewing bearing, which has stronger bearing capacity; turbine and worm adopts involute gears, so as to not only increase the efficiency and decrease the heat loss, but also realize the self-locking function.
3. Mechanical performance: it can realize the 360°two-way rotation, and it can meet the requirements just by adding a group of oil lines; and it can directly use the standard fork without needing any modification.
4. Applicable scope: it's widely used in food, automatic production, chemical, materials recycle, melting casting and other industries, and the sites need rotating to tip and mix the hoppers or boxes, and it can tip or change the cargoes quickly, and then bring back the fork to the original position immediately and consistently.

### LDSJ® L-series Rotator

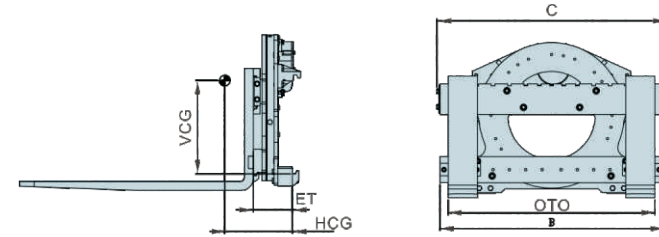

Suitable for non-casting industry

Capacity@ Load Center	Catalog Order No.	Overall width	Carriage Width	Fork Pocket Width	Fork Max Spacing	Mounting Class	Effective Thickness	Horizontal Center Gravity	Vertical Center Gravity	Weight	Available Forklift
(Kg@mm)		C (mm)	B (mm)	(mm)	(mm)		ET (mm)	HCG (mm)	VCG (mm)	(kg)	(t)
1700@500	XZ17L-A1	843	815	100	725	II/II	128	61	215	200	1-2.5t
2200@500	XZ22L-A2	975	942	100/122	862	II/II	194	102	297	270	2-2.5t
3000@500	XZ30L-B1	1180	1145	125	1062	III/III	194	121	310	362	3-4.5t
3500@500	XZ35L-B1	1275	1240	125/150	1160	III/III	210	169	310	383	3-4.5t
5400@500	XZ60L-C1	1585	1550	150	1470	IV/IV	233	139	322	640	5-7t

- Notes:
1. Please gain the actual overall carrying capacity of forklift truck attachments from the forklift truck manufacturers.
  2. It can add forks according to the needs of users, and please pay attention to the bearing capacity of the fork itself.
  3. Forklift truck needs to add a group of additional oil lines.
  4. Forks equipped for rotators must be welded with middle hooks, and the whole machine of rotators out of factory shall be attached with middle hooks.
  5. Rotators applicable for metallurgic industry can be provided with fitted forks. Please contact our sales department for more information.

Model	Pressure Value Bar		Flow Value L/min		
	Min.	Max.	Min.	Recommend	Max.
XZ17L-A1	35	160	19	26	38
XZ22L-A2	35	160	19	38	57
XZ30L-B1	35	160	19	38	57
XZ35L-B1	35	160	19	38	57
XZ60L-C1	35	160	38	57	76

  

Model	Rotating speed	Torque
XZ17L-A1	7.5r/min@38L/min	4200N.m@160Bar
XZ22L-A2	5.2r/min@57L/min	9000N.m@160Bar
XZ30L-B1	5.2r/min@57L/min	9000N.m@160Bar
XZ35L-B1	5.2r/min@57L/min	9000N.m@160Bar
XZ60L-C1	4.1r/min@57L/min	11000N.m@160Bar

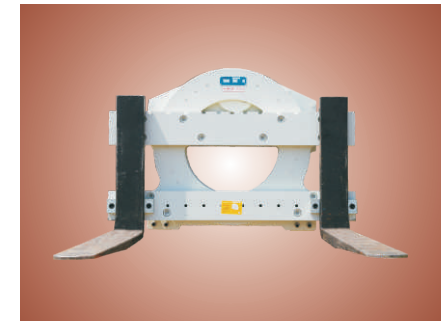

### Configuration of Key Parts of Truck Attachments

1. Hydraulic system: all the motors, valves and seals adopt originally imported products.
2. Structural part: it adopts large-modulus slewing bearing, which has stronger bearing capacity; turbine and worm adopts involute gears, so as to not only increase the efficiency and decrease the heat loss, but also realize the self-locking function.
3. Mechanical performance: it can realize the 360°two-way rotation, and it can meet the requirements just by adding a group of oil lines; and it can directly use the standard fork without needing any modification.
4. Applicable scope: it's widely used in food, automatic production, chemical, materials recycle, melting casting and other industries, and the sites need rotating to tip and mix the hoppers or boxes, and it can tip or change the cargoes quickly, and then bring back the fork to the original position immediately and consistently.

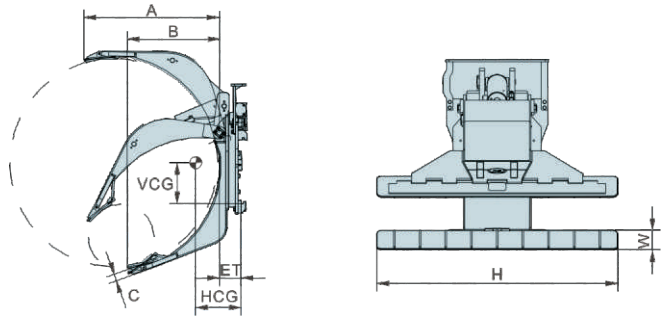

Capacity	Catalog Order No.	Mounting Class	Roll Range	Long Arm Length	Short Arm Length	Weight	Effective Thickness	Vertical Center of Gravity	Horizontal Center of Gravity	Arm Thickness	Contact Pad Size	Available Forklift
Kg			(mm)	A (mm)	B (mm)	(kg)	ET (mm)	VCG (mm)	HCG (mm)	C (mm)	W×H (mm)	(t)
1200	<b>LT12G-A1</b>	II	410-1300	858	575	470	135	330	335	45	250×1500	1-2.5t
1200	<b>LT12G-B1</b>	III	410-1300	858	575	472	135	330	340	45	250×1500	3-4.5t
1200	<b>LT12G-A2</b>	II	410-1300	858	575	490	135	300	340	45	250×1600	1-2.5t
1700	<b>LT17G-B1</b>	III	680-1830	1225	815	927	240	410	380	45	250×1500	3-4.5t
1700	<b>LT17G-C2</b>	IV	380-1830	1225	815	1000	253	333	420	45	250×1500	5-7t
2000	<b>LT20G-B4</b>	III	300-1600	1035	786	920	240	430	415	45	250×1500	3-4.5t
2000	<b>LT20G-B5</b>	III	600-1600	1035	786	900	240	428	410	45	250×1500	3-4.5t
2000	<b>LT20G-B9</b>	III	630-1520	1005	700	800	240	400	415	45	250×1500	3-4.5t

Notes:1. Please gain the actual overall carrying capacity of forklift trucks/ attachments from the forklift truck manufacturers.  
2. Forklift truck needs to add two groups of additional oil lines so as to match the attachments.

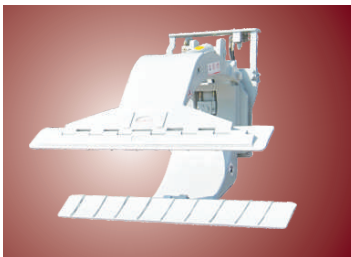

Model	Pressure Value Bar		Flow Value L/min					
	Min.	Max.	Min.	Recommend	Max.	Min.	Recommend	Max.
<b>LT**G</b>	35	160	19	26	38	19	26	38

### Configuration of Key Parts of Truck Attachments

1. Hydraulic system: all motors and other key hydraulic components adopt originally imported hydraulic products; all the seals adopt imported products; and the high-pressure rubber hoses adopt cone sealed high-performance imported rubber hoses.
2. Structural part: it adopts large-modulus slewing bearing, which has stronger bearing capacity; turbine and worm adopts involute gears, so as to not only increase the efficiency and decrease the heat loss, but also realize the self-locking function.
3. Mechanical performance: it can realize the 360°two-way rotation, and it adopts two-way hydraulic locks for rotating oil lines so as to realize two-way hydraulic self-locking and ensure the safety at work. And it adds hydraulic control check valve for each oil cylinder to realize holding pressure for a long time; and the clamp arm body adopts high-strength steels, so as to ensure the strength of clamp arm at work.

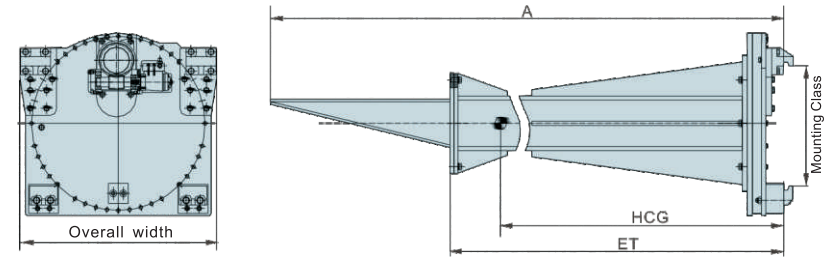

Capacity@ Load Center	Catalog Order No.	Overall Width	Overall Length	Mounting Class	Effective Thickness	Weight	Horizontal Center of Gravity	Shovel Pyle	Available Forklift
(Kg@mm)		(mm)	A (mm)		ET (mm)	(kg)	(mm)		(t)
1500@2780	<b>SL15G-B1</b>	986	3230	III	2310	1010	1250	wedge	3-4.5t
600@3460	<b>SL06G-C1</b>	986	3760	IV	3162	1000	1300	wedge	5-7t
800@2780	<b>SL08G-C1</b>	986	3200	IV	2500	1100	1550	wedge	5-7t
1000@3000	<b>SL10G-B1</b>	986	3704	III	2604	1200	1370	hopper	3-4.5t
1000@3470	<b>SL10G-C1</b>	986	3700	IV	3240	1120	1310	flat shovel	5-7t
1000@3000	<b>SL10G-C2</b>	986	3690	IV	2465	1066	1070	fork	5-7t
1000@3000	<b>SL10G-C3</b>	986	3705	IV	2635	1100	1025	fork	5-7t
1000@2780	<b>SL10G-C4</b>	986	3700	IV	2465	1100	1046	fork	5-7t
1000@2780	<b>SL10G-C5</b>	986	3675	IV	2870	1000	975	fork	5-7t
1500@2780	<b>SL15G-B2</b>	986	3204	III	2225	1050	960	fork	3-4.5t
1500@2780	<b>SL15G-C1</b>	986	3230	IV	2310	1020	1020	wedge	5-7t
1500@3000	<b>SL15G-C2</b>	986	3200	IV	2244	1010	1010	wedge	5-7t
1500@2900	<b>SL15G-C3</b>	986	3490	IV	2390	1120	1300	fork	5-7t
1500@3000	<b>SL15G-C4</b>	986	3380	IV	2380	1050	1250	wedge	5-7t
1500@3000	<b>SL15G-C5</b>	986	3600	IV	2898	1190	1334	fork	5-7t
1500@2500	<b>SL20G-C1</b>	986	3100	IV	2000	1100	866	fork	5-7t

Notes:1. Please gain the actual overall carrying capacity of forklift trucks/ attachments from the forklift truck manufacturers.  
2. Forklift truck needs to add one groups of additional oil lines so as to match the attachments.

Model	Pressure Value Bar		Flow Value L/min		
	Min.	Max.	Min.	Recommend	Max.
<b>SL**G</b>	35	160	19	38	57

  

Model	Rotating speed	Torque
<b>SL**G</b>	4.1r/min@57L/min	11000Nm@16MPa



### Configuration of Key Parts of Truck Attachments

1. Hydraulic system: all motors and other key hydraulic components adopt originally imported hydraulic products; all the seals adopt imported products; and it adopts two-way hydraulic self-locking in the rotating oil lines so as to ensure the safety at work.
2. Structural part: it adopts large-modulus slewing bearing, which has stronger bearing capacity; turbine and worm adopts involute gears, so as to not only increase the efficiency and decrease the heat loss, but also realize the self-locking function.
3. Mechanical performance: it can realize the 360°two-way rotation, and it can meet the requirements just by adding a group of oil lines; and the main parts are welded by high-performance alloy steel plates.
4. Applicable scope: it can realize the safe operation of steel making or aluminum making companies under H remote distance and high temperature environment.

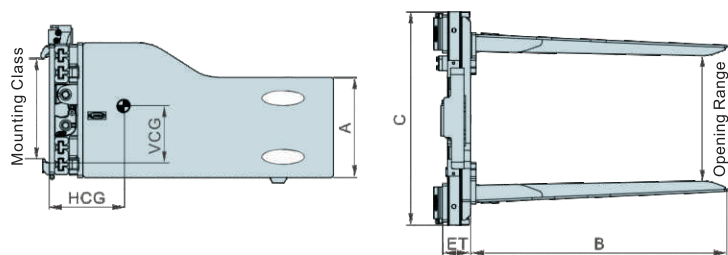

Capacity@ Load Center (Kg@mm)	Catalog Order No.	Opening Range (mm)	Arm Thickness (mm)	Mounting Class	Weight (kg)	Effective Thickness (mm)	Horizontal Center of Gravity (mm)	Vertical Ctr. of Gravity (mm)	Arm Height (mm)	Arm length (mm)	Overall Height Minimum Truck CarriageWidth (mm)	Frame Width (mm)	Available Forklift (t)
2200@500	RJ20J-A1	615-1925	100	II	580	159	313	247	550	1200	745	920	1010 1-2.5t
2200@500	RJ20J-B1	615-1925	100	III	540	159	277	240	475	1200	745	950	1010 3-4.5t
2200@500	RJ20J-B2	510-2375	100	III	660	159	237	240	475	1200	765	1040	1680 3-4.5t

- Notes: 1. Please gain the actual overall carrying capacity of forklift trucks/ attachments from the forklift truck manufacturers.  
 2. Forklift truck needs to add two groups of additional oil lines so as to match the attachments.  
 3. The arm thickness is the needed minimum wedge gap size when clamping, but not the real thickness.



Model	Pressure Value Bar		Flow Value L/min					
	Min.	Max.	Sideshift action		Clamping action			
			Min.	Recommend	Max.	Min.	Recommend	Max.
RJ**J	35	160	4	23	40	15	38	40

#### Configuration of Key Parts of Truck Attachments

- Hydraulic system: the load keeping valves of the main control valves adopt originally imported products; all the seals adopt imported products; and the high-pressure rubber hoses adopt cone sealed high-performance rubber hoses.
- Structural part: the left and right clamping panels adopt high-performance alloy steel plates, and the connection blocks are integrally charged by high-strength plates with good anti-bending performance.
- Mechanical performance: it's equipped with side shifting function inside, which can realize the clamping/opening and side shifting functions simultaneously with good view.
- Applicable scope: it can handle almost all kinds of bales efficiently and economically, such as cotton, wool, hay, and crushed aggregates, etc.

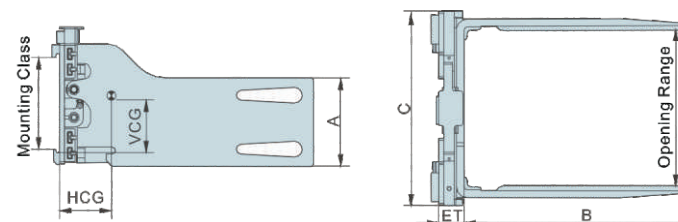

Capacity@ Load Center (Kg@mm)	Catalog Order No.	Mounting Class	Opening Range (mm)	Arm Thickness (mm)	Arm Height (mm)	Arm Length (mm)	Frame Width (mm)	Overall Height (mm)	Minimum Truck Carriage Width (mm)	Weight (kg)	Effective Thickness (mm)	Vertical Center of Gravity (mm)	Horizontal Center of Gravity (mm)	Available Forklift (t)
1800@500	RJ18ST-A1	II	460-1680	70	418	1190	1040	685	825	520	117	177	330	1-2.5t
1900@500	RJ18ST-A2	II	580-1960	70	418	1190	1100	685	900	530	117	177	323	1-2.5t
1900@500	RJ18ST-A3	II	460-1740	70	418	1190	1040	647	825	520	117	177	328	1-2.5t
1900@500	RJ18ST-B1	III	460-1740	70	418	1190	1040	690	885	530	122	226	320	3-4.5t
2200@500	RJ22ST-B1	III	460-2325	75	460	1200	1680	750	1040	715	132	237	263	3-4.5t
2200@500	RJ22ST-B2	III	600-2465	75	460	1200	1680	750	1040	750	132	241	254	3-4.5t
2700@500	RJ25ST-B1	III	565-1880	75	460	1200	1010	750	1000	650	132	228	318	3-4.5t
2700@500	RJ25ST-B5	III	555-1925	75	460	1200	1100	750	1000	670	132	232	313	3-4.5t
2700@500	RJ25ST-B17	III	550-2125	75	460	1200	1265	750	1030	710	132	233	298	3-4.5t

- Notes: 1. Please gain the actual overall carrying capacity of forklift trucks/ attachments from the forklift truck manufacturers.  
 2. Forklift truck needs to add two groups of additional oil lines so as to match the attachments.  
 3. The arm thickness is the needed minimum wedge gap size when clamping, but not the real thickness.

Model	Pressure Value Bar		Flow Value L/min					
	Max.		Sideshift action		Clamping action			
			Min.	Recommend	Max.	Min.	Recommend	Max.
RJ**ST	160		4	23	40	15	38	40



#### Configuration of Key Parts of Truck Attachments

- Hydraulic system: the load keeping valves of the main control valves adopt originally imported products; all the seals adopt imported products; and the high-pressure rubber hoses adopt cone sealed high-performance rubber hoses.
- Structural part: the left and right clamping panels adopt high-performance alloy steel plates, and the connection blocks are integrally charged by high-strength plates with good anti-bending performance.
- Mechanical performance: it's equipped with side shifting function inside, which can realize the clamping/opening and side shifting functions simultaneously with good view; and it can meet the use requirements by adding two groups of oil lines.
- Applicable scope: it can handle almost all kinds of bales efficiently and economically, such as cotton, wool, textile fibers, corrugated plates, white board paper, rags, hay, and industrial scraps, etc...

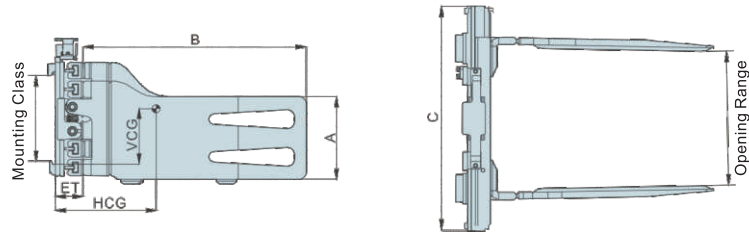

Capacity@ Load center	Catalog Order No.	Mounting Class	Opening Range	Arm Thickness	Arm Height	Arm Length	Frame Width	Weight	Effective Thickness	Minimum Truck Carriage width	Overall Height	Vertical Center of Gravity	Horizontal Center of Gravity	Available Forklift
Kg			(mm)	(mm)	E (mm)	B (mm)	C (mm)	(kg)	ET (mm)	(mm)	(mm)	VCG (mm)	HCG (mm)	(t)
2000@500	RJ20ST-A2	II	740-2110	75	460	1220	1250	800	154	1000	807	210	320	1-2.5t
2500@500	RJ25ST-A2	II	440-2305	75	460	1220	1700	860	154	1000	807	220	300	1-2.5t
2500@500	RJ25ST-B2	III	440-2305	75	460	1220	1700	890	154	1000	807	235	295	3-4.5t
2500@500	RJ25ST-B10	III	590-2455	75	460	1220	1700	890	154	1000	807	235	295	3-4.5t
3000@500	RJ30ST-A3	II	520-1880	75	460	1220	1130	750	154	1000	807	233	324	1-2.5t
3000@500	RJ30ST-B1	III	740-2110	75	460	1220	1250	790	154	1000	807	232	295	3-4.5t
3000@500	RJ30ST-B5	III	520-1880	75	460	1220	1130	750	154	1000	807	230	324	3-4.5t
3000@500	RJ30ST-C2	IV	535-2135	75	460	1220	1370	860	154	1000	955	233	288	5-7t

- Notes: 1. Please gain the actual overall carrying capacity of forklift trucks/attachments from the forklift truck manufacturers.  
 2. Forklift truck needs to add two groups of additional oil lines so as to match the attachments.  
 3. The arm thickness is the needed minimum wedge gap size when clamping, but not the real thickness.



Model	Pressure Value Bar		Flow Value L/min				
	Max.	Min. Recommend	Max.	Min.	Recommend	Max.	
RJ**ST	160	4	23	40	15	38	40

### Configuration of Key Parts of Truck Attachments

- Hydraulic system: the load keeping valves of the main control valves adopt originally imported products; all the seals adopt imported products; and the high-pressure rubber hoses adopt cone sealed high-performance rubber hoses.
- Structural part: the left and right clamping panels adopt high-performance alloy steel plates, and the connection blocks are integrally charged by high-strength plates with good anti-bending performance.
- Mechanical performance: it's equipped with side shifting function inside, which can realize the clamping/opening and side shifting functions simultaneously with good view; and it can meet the use requirements by adding two groups of oil lines.
- Applicable scope: it can handle almost all kinds of bales efficiently and economically, such as cotton, wool, textile fibers, corrugated plates, white board paper, rags, hay, and industrial scraps, etc...

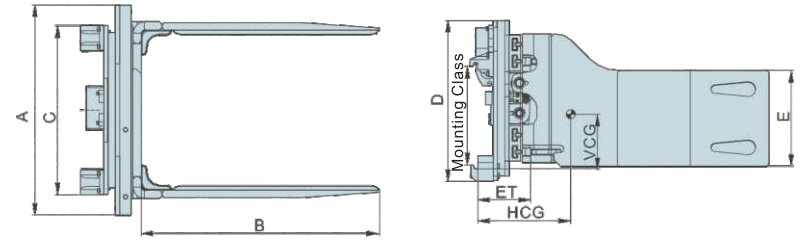

Capacity@ Load Center	Catalog Order No.	Mounting Class	Opening Range	Arm Thickness	Arm Height	Arm Length	Frame Width	Overall Height	Weight	Effective Thickness	Vertical Center of Gravity	Horizontal Center of Gravity	Available Forklift
(Kg@mm)			(mm)	(mm)	E (mm)	B (mm)	A (mm)	D (mm)	(kg)	ET (mm)	VCG (mm)	HCG (mm)	(t)
2700@500	RJ30RT-B1	III	565-1880	75	460	1200	1010	769	750	259	388	306	3-4.5t
1900@500	RJ19RT-A2	II	460-1680	70	418	1190	1040	769	760	257	302	343	1-2.5t
2700@500	RJ30RT-B2	III	650-2020	75	460	1200	1100	769	900	259	337	318	3-4.5t

- Notes: 1. Please gain the actual overall carrying capacity of forklift trucks/attachments from the forklift truck manufacturers.  
 2. Forklift truck needs to add two groups of additional oil lines so as to match the attachments.  
 3. The arm thickness is the needed minimum wedge gap size when clamping, but not the real thickness.

Model	Pressure Value Bar		Flow Value L/min					
	Min.	Max.	Min. Recommend	Max.	Min. Recommend	Max.		
RJ**RT	35	160	19	38	57	26	38	57

  

Model	Rotating speed		Torque	
	Min.	Max.	Min.	Max.
RJ**RT-A	3.5r/min@38L/min		4200N.m@160Bar	
RJ**RT-B	5.2r/min@57L/min		9000N.m@160Bar	



### Configuration of Key Parts of Truck Attachments

- Hydraulic system: it adopts two-way hydraulic locks for rotating oil lines so as to realize two-way hydraulic self-locking and ensure the safety at work; all the motors, valves and seals adopt originally imported products, and the rotating oil hinge has the self-locking function; and the high-pressure rubber hoses adopt cone sealed high-performance rubber hoses.
- Structural part: the left and right clamping panels adopt high-performance alloy steel plates, and the connection blocks are integrally charged with high-strength plates with good anti-bending performance.
- Mechanical performance: it can realize the clamping/opening and rotating functions simultaneously with good view; and it can meet the use requirements by adding two groups of oil lines.
- Applicable scope: it can handle almost all kinds of bales efficiently and economically, such as cotton, wool, Textile fibers, corrugated plates, white board paper, rags, hay, and industrial scraps, etc...

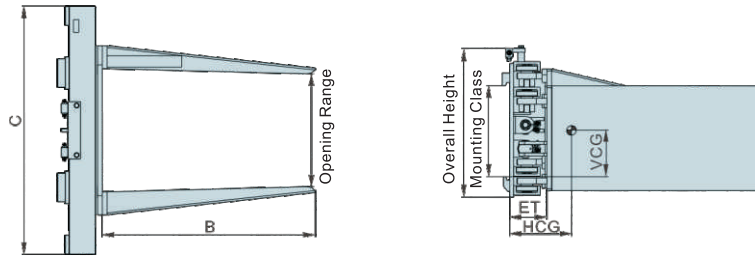

Capacity@ Load Center (Kg)	Catalog Order No.	Mounting Class	Opening Range (mm)	Arm Thickness (mm)	Arm Height (mm)	Arm Length (mm)	Frame Width (mm)	Weight (kg)	Effective Thickness (ET) (mm)	Overall Height (mm)	Horizontal Center of Gravity (HCG) (mm)	Notes	Available Forklift (t)
2000@500	<b>RJ20SC-B1-01</b>	III	610-1895	135	550	1200	1300	660	234	855	274	Without side shift	3-4.5t
2000@500	<b>RJ20SC-B3-01</b>	III	600-2225	135	550	1200	1450	700	234	855	264	Without side shift	3-4.5t

- Notes: 1. Please gain the actual overall carrying capacity of forklift trucks/attachments from the forklift truck manufacturers.  
 2. Forklift truck needs to add two groups of additional oil lines so as to match the attachments.  
 3. The arm thickness is the needed minimum wedge gap size when clamping, but not the real thickness.  
 4. RJ20SC-B1-01 and RJ20SC-B3-01 are slipper type economic bale clamp.



Model	Pressure Value Bar		Flow Value L/min	
	Max.	Min.	Recommend	Max.
<b>RJ**SC</b>	160	15	38	40

### Configuration of Key Parts of Truck Attachments

- Structural part: the left and right clamping panels and other key parts adopt high-strength plates, and the channel steels adopt high-performance forklift truck portal frame channel steels.
- Applicable scope: it can handle almost all kinds of bales efficiently and economically, such as cotton, wool, textile fibers, corrugated plates, white board paper, rags, hay, and industrial scraps, etc...

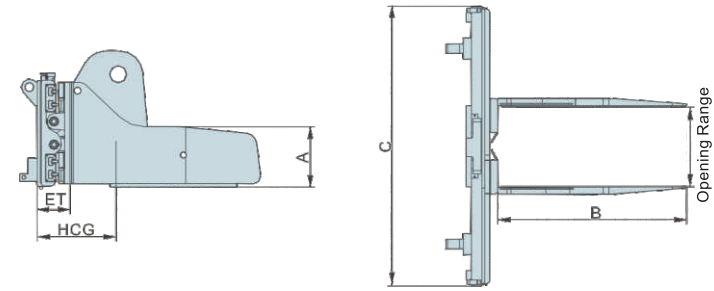

Capacity@ Load Center (Kg@mm)	Catalog Order No.	Mounting Class	Opening Range (mm)	Arm Thickness (mm)	Arm Height (mm)	Arm Length (mm)	Frame Width (mm)	Overall Height (mm)	Weight (kg)	Horizontal Center of Gravity (HCG) (mm)	Effective Thickness (ET) (mm)	Available Forklift (t)
6500@800	<b>ZB65G-X1-01</b>	String type	600-3170	105	585	1590	2420	1190	2600	493	297	12t
4000@600	<b>ZB40R-C1</b>	Mounted	625-2175	90	518	1200	1300	915	1650	403	367	5-7t
4000@600	<b>ZB40G-C1</b>	Mounted	625-2175	90	518	1200	1300	1050	1300	313	209	5-7t
2500@500	<b>ZB25G-B1</b>	Mounted	635-1950	100	518	1200	1010	750	860	413	182	3-4.5t

- Notes: 1. Please gain the actual overall carrying capacity of forklift trucks/attachments from the forklift truck manufacturers.  
 2. Forklift truck needs to add two groups of additional oil lines so as to match the attachments.  
 3. ZB40R-C1 are revolving pulp bale clamps.  
 4. The arm thickness is the needed minimum wedge gap size when clamping, but not the real thickness.

Model	Pressure Value Bar			Flow Value L/min			
	Min.	Min. Recommend	Max.	Min.	Recommend	Max.	
<b>ZB25G</b>	160	4	23	40	15	38	40
<b>ZB40G</b>	160	4	23	57	26	45	57
<b>ZB65G</b>	160	36	57	91	60	70	80

  

Model	Rotating action			Clamping action			
	Max.	Min. Recommend	Max.	Min. Recommend	Max.	Max.	
<b>ZB40R</b>	160	19	38	57	26	45	57



### Configuration of Key Parts of Truck Attachments

- Hydraulic system: the load keeping valves of the main control valves adopt originally imported products; all the seals adopt imported products; and the high-pressure rubber hoses adopt cone sealed high-performance rubber hoses.
- Structural part: the left and right clamping panels adopt high-performance alloy steel plates.
- Mechanical performance: it's equipped with sideshifting function inside, which can realize the clamping/opening and sideshifting functions simultaneously with good view; and it can meet the use requirements by adding two groups of oil lines.
- Applicable scope: it can handle almost all kinds of bales efficiently and economically.

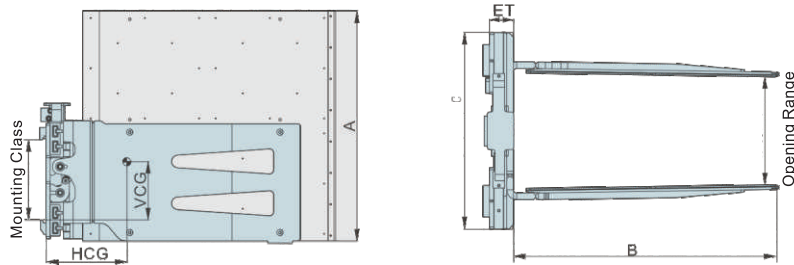

Capacity@ Load Center (Kg@mm)	Catalog Order No.	Mounting Class	Opening Range (mm)	Arm Thickness (mm)	Minimum Truck Carriage Width (mm)	Arm Height A (mm)	Arm Length B (mm)	Frame Width C (mm)	Weight (kg)	Effective Thickness ET (mm)	Horizontal Center of Gravity HCG (mm)	Available Forklift (t)
1900@500	GJ18J-A1	II	530-1750	65	825	455	1075	1040	500	117	289	1-2.5t
1900@500	GJ18J-A2	II	485-1735	77	825	1100	1260	940	670	117	449	1-2.5t
2500@500	GJ27J-B1	III	580-1925	70	970	455	1090	1010	630	132	283	3-4.5t
2500@500	GJ27J-B2	III	580-1925	70	970	506	1055	1010	670	132	311	3-4.5t

- Notes: 1. Please gain the actual overall carrying capacity of forklift trucks/attachments from the forklift truck manufacturers.  
 2. Forklift truck needs to add two groups of additional oil lines so as to match the attachments.  
 3. The arm thickness is the needed minimum wedge gap size when clamping, but not the real thickness.

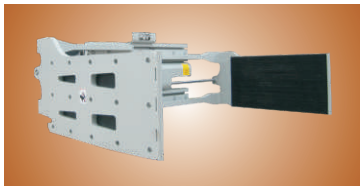

Model	Pressure Value Bar		Flow Value L/min				
	Max.	Min. Recommend	Max.	Min. Recommend	Max.		
GJ18J	160	4	15	26	15	26	26
GJ27J	160	4	23	38	15	38	38

### Configuration of Key Parts of Truck Attachments

1. Hydraulic system: the load keeping valves of the main control valves adopt originally imported products; all the seals adopt imported products; and the high-pressure rubber hoses adopt cone sealed high-performance imported rubber hoses.
2. Structural part: the left and right clamping panels adopt high-performance alloy steel plates.
3. Mechanical performance: it's equipped with sideshifting function inside, which can realize the clamping/opening and sideshifting functions simultaneously with good view; and it can meet the use requirements by adding two groups of oil lines.
4. Clamping rubber plates: easy for changing.
5. Applicable scope: it can handle various paper boxes, wood boxes, metal boxes or bales and other cargoes safely and efficiently; and it's applied to the non-pallet carrying or stacking operation in tobacco, paper making, chemical fibre, workshop, ports and other industries.

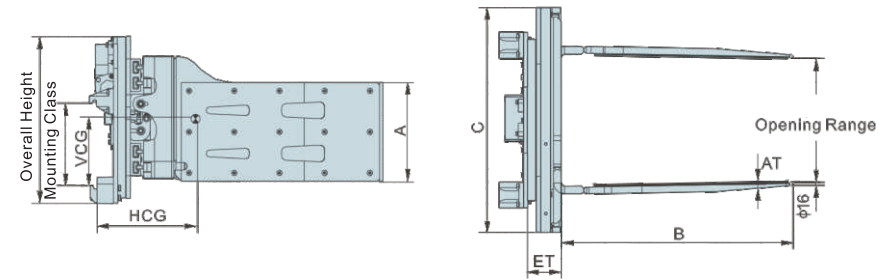

Capacity@ Load Center (Kg@mm)	Catalog Order No.	Mounting Class	Opening Range (mm)	Arm Thickness (mm)	Arm Height A (mm)	Arm Length B (mm)	Frame Width C (mm)	Overall Height (mm)	Arm Toe-in AT (mm)	Weight (kg)	Effective Thickness ET (mm)	Horizontal Center of Gravity HCG (mm)	Available Forklift (t)
1900@500	GJ19RT-A1	II	580-1780	70	455	1075	1040	774	25	750	252	315	1-2.5t
2500@500	GJ25RT-B1	III	580-1890	65	505	1060	1010	774	20	780	259	375	3-4.5t

- Notes: 1. Please gain the actual overall carrying capacity of forklift trucks/attachments from the forklift truck manufacturers.  
 2. Forklift truck needs to add two groups of additional oil lines so as to match the attachments.  
 3. The arm thickness is the needed minimum wedge gap size when clamping, but not the real thickness.

Model	Pressure Value Bar		Flow Value L/min					
			Rotating action		Clamping action			
	Min.	Max.	Min. Recommend	Max.	Min. Recommend	Max.		
GJ**RT	35	160	19	38	57	26	38	57

Model	Rotating speed	Torque
GJ**RT	5.2r/min@57L/min	9000N.m@160Bar

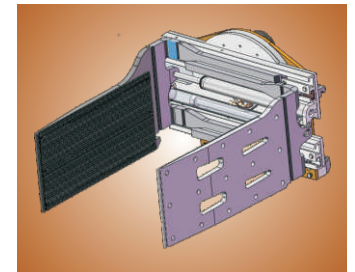

### Configuration of Key Parts of Truck Attachments

1. Hydraulic system: it adopts two-way hydraulic locks for rotating oil lines so as to realize two-way hydraulic self-locking and ensure the safety at work; all the motors, valves and seals adopt originally imported products, and the rotating oil hinge has self-locking function; and the high-pressure rubber hoses adopt cone sealed high-performance rubber hoses.
2. Structural part: the left and right clamping panels adopt high-performance alloy steel plates, link blocks are overall discharge of high strength plate or forgings for whole.
3. Mechanical performance: it can realize the clamping/opening and revolving functions simultaneously with good view; and it can meet the use requirements by adding two groups of oil lines.
4. Applicable scope: it can handle various paper boxes, wood boxes, metal boxes or bales and other cargoes safely and efficiently; and it's applied to the non-pallet carrying or stacking operation in tobacco, paper making, chemical fibre, workshop, ports and other industries.



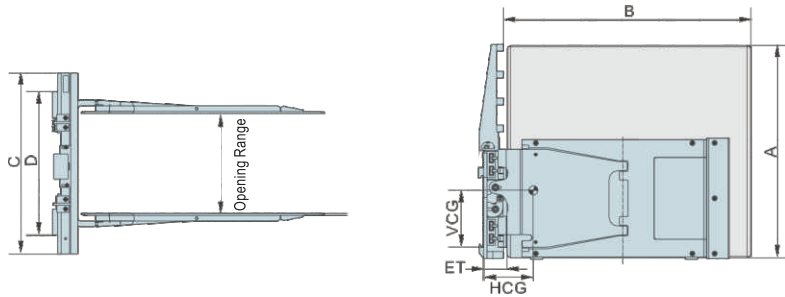

Capacity@ Load Center (Kg@mm)	Catalog Order No.	Mounting Class	Opening Range (mm)	Arm Thickness (mm)	Arm Height A (mm)	Arm Length B (mm)	Frame Width C (mm)	Hook Spread D (mm)	Effective Thickness ET (mm)	Vertical Center of Gravity VCG (mm)	Horizontal Center of Gravity HCG (mm)	Weight (kg)	Available Forklift (t)
1400@700	ZX14J-A1	II	560-1940	90	1200	1420	1040	825	117	371	504	875	2-2.5t
1400@700	ZX14J-A2	II	760-2140	90	1200	1420	1040	825	117	369	497	890	2-2.5t
1400@700	ZX14J-A3	II	590-1970	90	1200	1480	1040	825	117	369	534	900	2-2.5t
1200@600	ZX12J-A1	II	400-1570	90	1200	1220	1040	825	117	368	429	785	2-2.5t
1400@600	ZX14J-A4	II	565-1945	90	1200	1220	1040	825	117	367	424	800	2-2.5t
1400@600	ZX14J-B1	III	595-1975	90	1200	1220	1040	1025	117	367	424	800	3-4.5t

- Notes: 1. Please gain the actual overall carrying capacity of forklift trucks/attachments from the forklift truck manufacturers.  
 2. Forklift truck needs to add two groups of additional oil lines so as to match the attachments.  
 3. The whole machine is equipped with four-gear pressure regulating valve when delivered from factory.  
 4. The arm thickness is the needed minimum wedge gap size when clamping, but not the real thickness.

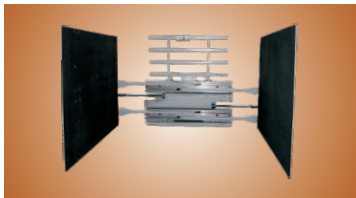

Model	Pressure Value Bar	Flow Value L/min					
	Max.	Sideshift action		Clamping action			
		Min.	Recommend	Max.	Min.	Recommend	Max.
ZX**J	160	4	15	38	19	26	38

#### Configuration of Key Parts of Truck Attachments

- Hydraulic system: all key hydraulic components adopt originally imported hydraulic products; all the seals adopt imported products; and the high-pressure rubber hoses adopt cone sealed high-performance imported rubber hoses; and four-gear pressure regulating valve can be used to set different suitable clamping power according to different cargoes.
- Mechanical performance: it's equipped with sideshifting function inside, which can realize the clamping/opening and sideshifting functions simultaneously with good view; and it can meet the use requirements by adding two groups of oil lines.
- Structural part: the left and right clamping panels adopt high-performance aluminum alloy plates to reduce the weight; and the connection block is integrally charged with high-strength plates with good anti-bending performance.
- Applicable scope: it's applied to the high-efficient and non-pallet carrying of carton packaging products in the warehouse, beverage, household appliance and electronics industries, which save the expenses of purchasing, and maintaining pallets as well as the warehouse space.

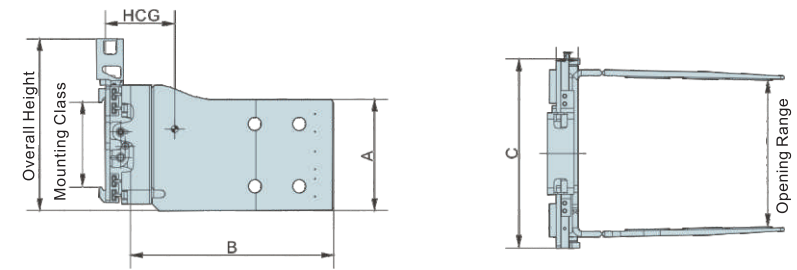

Capacity@ Load Center (Kg@mm)	Catalog Order No.	Mounting Class	Opening Range (mm)	Arm Thickness (mm)	Arm Height A (mm)	Arm Length B (mm)	Frame Width (mm)	Overall Height (mm)	Weight (kg)	Effective Thickness ET (mm)	Horizontal Center of Gravity HCG (mm)	Available Forklift (t)
1800@500	YX18G-A6	II	540-1900	60	700	1000	1170	732	620	147	332	2-2.5t
1800@500	YX18G-A7	II	540-1900	65	700	1100	1170	732	630	147	368	2-2.5t
1800@500	YX18G-A8	II	465-1745	65	565	1150	1040	670	560	117	367	1-2.5t
1800@500	YX18G-A9	II	500-1680	65	500	1100	1040	675	520	147	332	1-2.5t
1800@500	YX18G-A10	II	500-1680	65	580	1100	1040	765	660	147	361	1-2.5t
2200@500	YX22G-B1	III	540-1900	65	700	1100	1170	765	660	152	361	3-4.5t

- Notes: 1. Please gain the actual overall carrying capacity of forklift trucks/attachments from the forklift truck manufacturers.  
 2. Forklift truck needs to add two groups of additional oil lines so as to match the attachments.  
 3. The arm thickness is the needed minimum wedge gap size when clamping, but not the real thickness.

Model	Pressure Value Bar	Flow Value L/min					
	Max.	Sideshift action		Clamping action			
		Min.	Recommend	Max.	Min.	Recommend	Max.
YX18G	160	4	15	26	15	26	26
YX22G	160	4	23	38	19	26	38

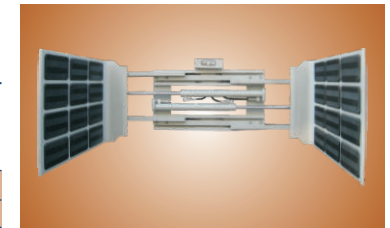

#### Configuration of Key Parts of Truck Attachments

- Hydraulic system: the load keeping valves of the main control valves adopt originally imported products; all the seals adopt imported products; and the high-pressure rubber hoses adopt cone sealed high-performance imported rubber hoses.
- Structural part: the left and right clamping panels adopt high-performance alloy steel plates, which are integrally profiled and corrected, and have good anti-bending performance.
- Mechanical performance: it can realize the clamping/opening and sideshifting functions simultaneously with good view; and it can meet the use requirements by adding two groups of oil lines.
- Applicable scope: tobacco carton clamps are the high-efficiency and non-pallet tobacco handling forklift truck attachments specified for the tobacco industry, it's especially suitable for handling the redried tobacco cartons of threshing and redrying factories, cigarettes factories and other sites. And it can clamp one, two, four and six tobacco cartons, so as to effectively increase the warehouse space utilization ratio, avoid the damage of cartons, and reduce the logistic costs as well as further increase the production efficiency significantly.

## LDSJ® Revolving(Side-shift) Tobacco Carton Clamps

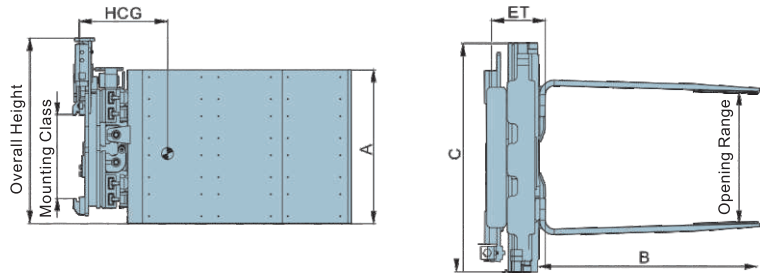

Capacity@ Load Center (Kg@mm)	Catalog Order No.	Mounting Class	Opening Range (mm)	Arm Thickness (mm)	Arm Height A (mm)	Arm Length B (mm)	Weight (kg)	Frame Width C (mm)	Effective Thickness ET (mm)	Overall Height (mm)	Horizontal Center of Gravity HCG (mm)	Notes	Available Forklift (t)
800@500	<b>YX16RC-A1</b>	II	585-1880	60	700	1000	760	1040	225	844	325	Rotating Sideshift	2-2.5t
1900@500	<b>YX19RT-B1</b>	III	480-1760	70	565	1140	780	1040	263	772	385	Rotating	3-4.5t
2500@500	<b>YX25RT-B1</b>	III	615-1930	60	700	1000	740	1010	202	700	372	Rotating	3-4.5t

- Notes: 1. Please gain the actual overall carrying capacity of forklift trucks/attachments from the forklift truck manufacturers.  
 2. Forklift truck needs to add two groups of additional oil lines so as to match the attachments.  
 3. The arm thickness is the needed minimum wedge gap size when clamping, but not the real thickness.

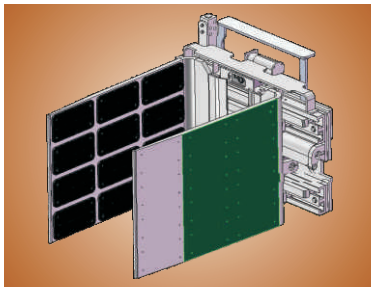

Model	Pressure Value Bar			Flow Value L/min		
	Min.	Max.	Recommend	Min.	Recommend	Max.
<b>YX**RC(T)</b>	35	160	19	26	38	38

Model	Rotating speed		Torque	
	Min.	Recommend	Min.	Recommend
<b>YX**RC(T)-A</b>	3.5/min	@38L/min	4200N.m	@160Bar
<b>YX**RC(T)-B</b>	5.2/min	@57L/min	9000N.m	@160Bar

### Configuration of Key Parts of Truck Attachments

- Hydraulic system: all the motors, valves and seals adopt originally imported products; and the high-pressure rubber hoses adopt cone sealed high-performance imported rubber hoses.
- Structural part: the left and right clamping panels adopt high-performance alloy steel plates, which are integrally profiled and corrected, and have good anti-bending performance.
- Mechanical performance: it's equipped with sideshifting functions inside, which can realize the clamping/opening and sideshifting or revolving functions simultaneously with good view; and it can meet the use requirements by adding two groups of oil lines.

## LDSJ® Fork Clamps

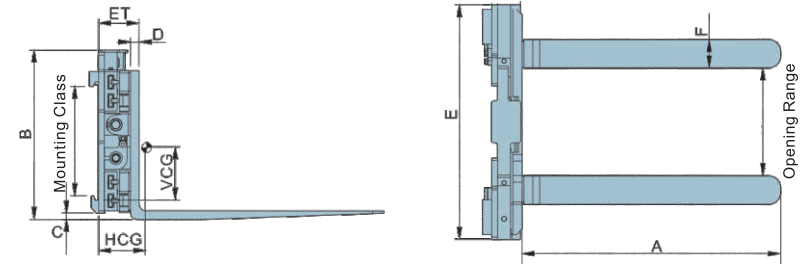

Capacity@ Load Center (Kg@mm)	Catalog Order No.	Mounting Class	Opening Range (mm)	Frame Width E (mm)	Fork Length A (mm)	Fork Width F (mm)	Fork Thickness D (mm)	Weight (kg)	Vertical Center of Gravity VCG (mm)	Horizontal Center of Gravity HCG (mm)	Effective Thickness ET (mm)	Available Forklift (t)	Note
1600@600	<b>CJ16G-A1</b>	II	400-1625	1040	1070	100	35	320	155	170	167	1-2.5t	/
1600@600	<b>CJ16G-A2</b>	II	400-1625	1040	1220	100	35	330	161	170	167	1-2.5t	/
2300@600	<b>CJ23G-B1</b>	III	505-1820	1010	1070	125	45	440	214	163	186	3-4.5t	/
2300@600	<b>CJ23R-B2</b>	III	410-1780	1100	1070	150	50	765	323	164	318	3-4.5t	Rotating
2300@600	<b>CJ23G-B5</b>	III	505-1820	1010	1200	125	45	450	250	193	186	3-4.5t	/
4000@600	<b>CJ40G-C1</b>	IV	480-2030	1300	1670	150	60	1000	475	265	236	5-7t	/

- Notes: 1. Please gain the actual overall carrying capacity of forklift trucks/attachments from the forklift truck manufacturers.  
 2. Forklift truck needs to add two groups of additional oil lines so as to match the attachments.  
 3. CJ23R-B2 fork clamps are revolving fork clamps.

Model	Pressure Value Bar			Flow Value L/min		
	Max.	Min.	Recommend	Max.	Min.	Recommend
<b>CJ16G</b>	160	4	15	26	15	26
<b>CJ23G</b>	160	4	23	38	15	38
<b>CJ40G</b>	160	4	23	57	26	45



### Configuration of Key Parts of Truck Attachments

- Hydraulic system: the load keeping valves of the main control valves adopt originally imported products; all the seals adopt imported products; and the high-pressure rubber hoses adopt cone sealed high-performance imported rubber hoses.
- Structural part: the clamp arms adopt alloy steel castings, and the guide rail assembly is welded by high-performance alloy steel plates, which has good anti-bending performance.
- Mechanical performance: it's equipped with sideshifting functions inside, which can realize the clamping/opening and sideshifting functions simultaneously with good view; and it can meet the use requirements by adding two groups of oil lines.
- Applicable scope: it can not only be used to clamp cargoes, but also the forklift truck pallet cargoes.

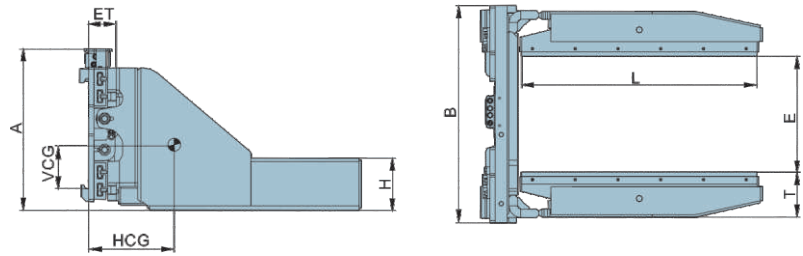

Capacity@ Load Center (Kg@mm)	Catalog Order No.	Opening Range (mm)	Arm Height H (mm)	Arm Length L (mm)	Arm Thickness T (mm)	Frame Width B (mm)	Frame Height A (mm)	Weight (kg)	Hook spacing (mm)	Mounting Class	Effective Thickness ET (mm)	Horizontal Center of Gravity HCG (mm)	Available Forklift (t)	Vertical Center of Gravity VCG (mm)
2700@500	ZK27G-A1	310-1625	234	1100	202	1010	745	760	950	II	132	361	1-2.5t	171
2700@500	ZK27G-B1	330-1645	234	1470	197	1010	745	870	950	III	134	455	3-4.5t	169
2700@500	ZK27G-B2	310-1625	234	1100	202	1010	745	760	950	III	134	384	3-4.5t	163
2700@500	ZK27G-B3	320-1635	124	1100	195	1010	745	640	950	III	134	311	3-4.5t	174
2700@500	ZK27G-B6	320-1635	238	1260	195	1010	745	830	950	III	134	441	3-4.5t	155

Notes: 1. Please gain the actual overall carrying capacity of forklift trucks/attachments from the forklift truck manufacturers.  
2. Forklift truck needs to add two groups of additional oil lines so as to match the attachments.



Model	Pressure Value Bar		Flow Value L/min				
	Max.	Sideshift action	Clamping action	Min.	Recommend	Max.	
ZK**G	160	4	23	38	15	38	38

### Configuration of Key Parts of Truck Attachments

- Hydraulic system: the load keeping valves of the main control valves adopt originally imported products; all the seals adopt imported products; and the high-pressure rubber hoses adopt cone sealed high-performance imported rubber hoses.
- Structural part: the left and right clamping panels adopt high-performance alloy steel plates, and the connection plates are hot pressed by high-strength plates, which have good anti-deformation performance; the inside of clamp arms are equipped with replaceable high-wear- resistance rubber blocks.
- Mechanical performance: its equipped with sideshifting functions inside, which can realize the clamping/opening and sideshifting functions simultaneously with good view; and it can meet the use requirements by adding two groups of oil lines.

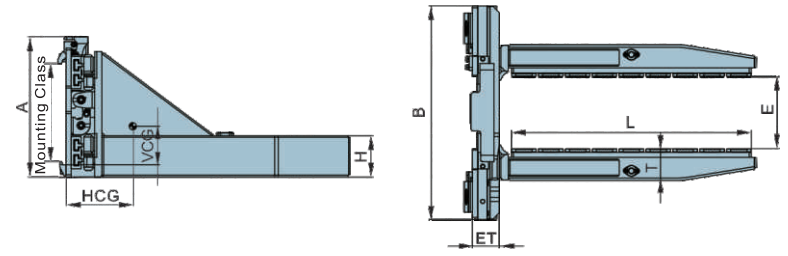

Capacity@ Load Center (Kg@mm)	Catalog Order No.	Opening Range (mm)	Mounting Class	Weight (kg)	Effective Thickness ET (mm)	Horizontal Center of Gravity HCG (mm)	Vertical Center of Gravity VCG (mm)	Arm Height H (mm)	Arm Length L (mm)	Arm Thickness T (mm)	Overall Height A (mm)	Minimum Truck Carriage Width (mm)	Frame Width B (mm)	Available Forklift (t)
1800@600	ZK15G-B1	350-1630	III	600	131	325	187	200	1170	155	680	980	1040	3-4.5t
2000@500	ZK20G-B1	425-1850	III	700	137	348	172	190	1280	200	730	980	1265	3-4.5t

Notes: 1. Please gain the actual overall carrying capacity of forklift trucks/attachments from the forklift truck manufacturers.  
2. Forklift truck needs to add two groups of additional oil lines so as to match the attachments.

Model	Pressure Value Bar		Flow Value L/min				
	Max.	Sideshift action	Clamping action	Min.	Recommend	Max.	
ZK**G	160	4	23	38	15	38	38



### Configuration of Key Parts of Truck Attachments

- Hydraulic system: the load keeping valves of the main control valves adopt originally imported products; all the seals adopt imported products; and the high-pressure rubber hoses adopt cone sealed high-performance imported rubber hoses.
- Structural part: the left and right clamping panels adopt high-performance alloy steel plates, and the connection plates are hot pressed by high-strength plates, which have good anti-deformation performance; the inside of clamp arms are equipped with replaceable high-wear- resistance rubber blocks.
- Mechanical performance: it's equipped with sideshifting functions inside, which can realize the clamping/opening and sideshifting functions simultaneously; clamping arm can touch the goods thoroughly to keep the action more reliable.

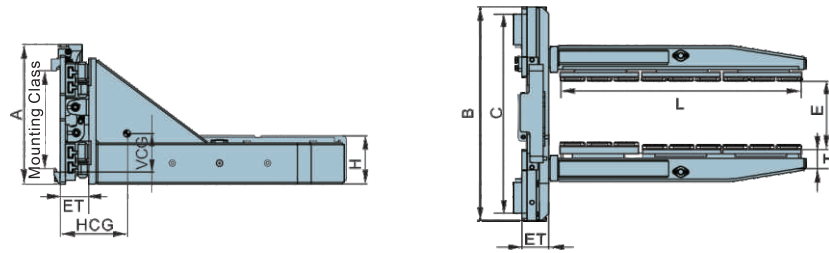

Capacity@ Load Center (Kg@mm)	Catalog Order No.	Opening Range (mm)	Mounting Class	Weight (kg)	Effective Thickness (mm)	Horizontal Center of Gravity (mm)	Vertical Center of Gravity (mm)	Arm Height (mm)	Arm Length (mm)	Arm Thickness (mm)	Overall Height (mm)	Minimum Truck Carriage Width (mm)	Frame Width (mm)
					ET	HCG	VCG	H	L	T	A		B
1800@600	ZK15F-B1	290-1600	III	680	132	339	139	160	1230	191	735	970	1100

- Notes: 1. Please gain the actual overall carrying capacity of forklift trucks/attachments from the forklift truck manufacturers.  
 2. Forklift truck needs to add two groups of additional oil lines so as to match the attachments.  
 3. The front splint can float in a single piece.



Model	Pressure Value Bar		Flow Value L/min				
	Max.	Sideshift action	Sideshift action		Clamping action		
			Min.	Recommend	Min.	Recommend	Max.
ZK**F	160	4	15	38	19	26	38

### Configuration of Key Parts of Truck Attachments

1. Hydraulic system: the seals are imported; the high-pressure hose adopts high-performance imported hose; the control valve can adjust the clamping force.
2. Structural part: The built-in side shift function can realize the clamping/opening and side shift functions at the same time, and the field of view is better; two sets of oil paths can be added to meet the requirements of use.
3. Mechanical performance: The left and right splints are made of high-performance alloy steel plate welded frame structure with high structural strength and good deformation resistance. The clamping arms are connected to the left and right clamp assemblies through the shaft system.

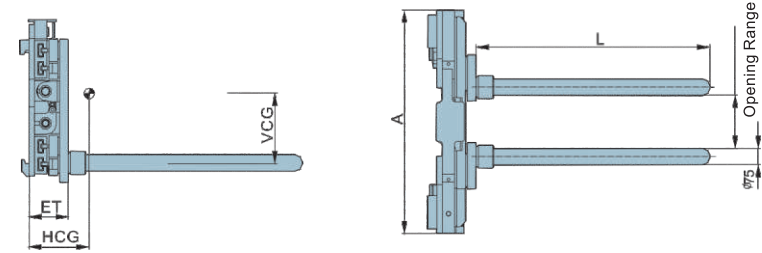

Capacity@ Load Center (Kg@mm)	Catalog Order No.	Mounting Class	Vertical Center of Gravity (mm)	Opening Range (mm)	Frame Width (mm)	Effective Thickness (mm)	Bar Arm Diameter (mm)	Bar Arm Length (mm)	Horizontal Center of Gravity (mm)	Weight (kg)	Available Forklift (t)
			VCG		A	ET	C	L	HCG		
1600@600	YG16G-A1	II	218	246-1400	1040	165	φ75	1500	241	400	1-2.5t
2300@600	YG23G-B1	III	213	240-1400	1010	179	φ75	1065	239	460	3-4.5t

- Notes: 1. Please gain the actual overall carrying capacity of forklift trucks/attachments from the forklift truck manufacturers.  
 2. Forklift truck needs to add two groups of additional oil lines so as to match the attachments.

Model	Pressure Value Bar		Flow Value L/min				
	Max.	Sideshift action	Sideshift action		Clamping action		
			Min.	Recommend	Min.	Recommend	Max.
YG16G	160	4	15	26	15	26	26
YG23G	160	4	23	38	15	38	38

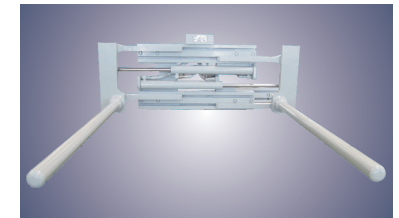

### Configuration of Key Parts of Truck Attachments

1. Hydraulic system: all key hydraulic components adopt originally imported hydraulic products; all the seals adopt imported products; and the high-pressure rubber hoses adopt cone sealed high-performance imported rubber hoses.
2. Mechanical performance: it's equipped with sideshifting functions inside, which can realize the clamping/opening and sideshifting functions simultaneously with good view; and it can meet the use requirements by adding two groups of oil lines.
3. Applicable scope: it's applied to the fork-taking, stacking and handling of drum-shaped cargoes.

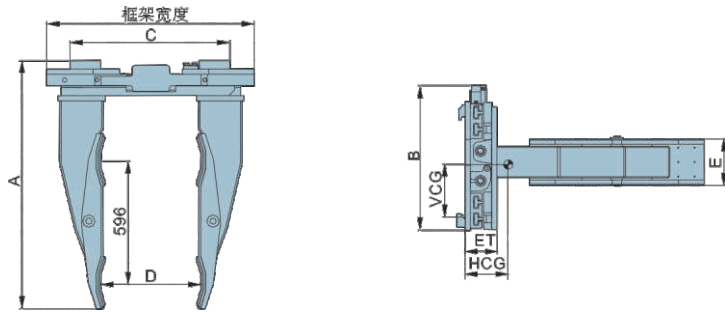

Capacity@ Load Center (Kg@mm)	Catalog Order No.	Mounting Class	Opening Range D (mm)	Arm Height E (mm)	Total length A (mm)	Hook Spread C (mm)	Frame Width (mm)	Overall Height B (mm)	Effective Thickness ET (mm)	Weight (kg)	Horizontal Center of Gravity HCG (mm)	Available Forklift (t)	Note
1400@500	TJ14S-A1	II	320-1540	230	1245	825	1040	550	138	440	243	2-2.5t	Four bucket clamp
1000@510	TJ10S-A1	II	400-1400	235	815	825	1040	660	138	380	144	1-2.5t	Single bucket clamp
1400@500	TJ14S-B1	III	320-1540	230	1255	1000	1040	677	143	458	233	3-4.5t	Four bucket clamp
1900@500	TJ19S-A1	II	520-1740	235	625	825	1040	650	138	340	97	2-2.5t	Two bucket clamp
1900@500	TJ19S-B1	III	520-1740	235	635	1000	1040	680	143	372	97	3-4.5t	Two bucket clamp

- Notes: 1. Please gain the actual overall carrying capacity of forklift trucks/attachments from the forklift truck manufacturers.  
 2. Forklift truck needs to add two groups of additional oil lines so as to match the attachments.  
 3. The following picture shows the four-barrel clip.



Model	Pressure Value Bar		Flow Value L/min					
	Min.	Max.	Sideshift action		Clamping action			
			Min.	Recommend	Max.	Min.	Recommend	Max.
TJ**S	35	160	4	11	21	15	21	38

#### Configuration of Key Parts of Truck Attachments

1. Hydraulic system: the load keeping valves of the main control valves adopt originally imported products; all the seals adopt imported products; and the high-pressure rubber hoses adopt cone sealed high-performance imported rubber hoses.
2. Structural part: the left and right clamping panels are welded by high-performance alloy steel plates; and the inside of clamp arms are covered with replaceable anti-skid rubber strips so as to prevent the oil barrels from damaging.
3. Mechanical performance: it's equipped with sideshifting function inside, which can realize the clamping/opening and sideshifting functions simultaneously, which is convenient for the placement of oil barrels and has good view; and it can meet the use requirements by adding two groups of oil lines.

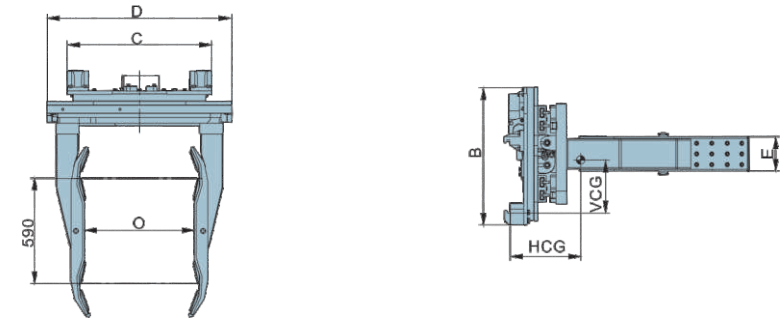

Capacity@ Load Center (Kg@mm)	Catalog Order No.	Mounting Class	Opening Range O (mm)	Arm Height E (mm)	Hook Spread C (mm)	Frame Width D (mm)	Weight (kg)	Effective Thickness ET (mm)	Overall Height B (mm)	Horizontal Center of Gravity HCG (mm)	Available Forklift (t)	Note	Vertical Center of Gravity VCG (mm)
1600@600	TJ19R-A1	II	470-1700	800	814	1040	815	275	800	380	1-2.5t	Four bucket clamp	325
1900@310	TJ19R-A2	II	520-1750	235	815	1040	480	194	807	142	1-2.5t	Two bucket clamp	251
1600@600	TJ19R-A3	II	470-1700	230	814	1040	670	275	774	279	1-2.5t	Four bucket clamp	324
1600@600	TJ19R-B1	III	470-1700	800	814	1040	815	275	800	380	3-4.5t	Four bucket clamp	334
1900@310	TJ19R-B2	III	520-1750	235	610	1040	500	226	889	142	3-4.5t	Two bucket clamp	325
1600@600	TJ19R-B3	III	470-1700	230	814	1040	670	275	774	279	3-4.5t	Four bucket clamp	332

- Notes: 1. Please gain the actual overall carrying capacity of forklift trucks/attachments from the forklift truck manufacturers.  
 2. Forklift truck needs to add two groups of additional oil lines so as to match the attachments.  
 3. The following picture shows the two-barrel clip.



Model	Pressure Value Bar		Flow Value L/min					
	Min.	Max.	Rotating action		Clamping action			
			Min.	Recommend	Max.	Min.	Recommend	Max.
TJ**R	35	160	19	38	57	26	26	38

#### Configuration of Key Parts of Truck Attachments

1. Hydraulic system: the load keeping valves of the main control valves adopt originally imported products; all the seals adopt imported products; and the high-pressure rubber hoses adopt cone sealed high-performance imported rubber hoses.
2. Structural part: the left and right clamping panels are welded by high-performance alloy steel plates; and the inside of clamp arms are covered with replaceable anti-skid rubber strips so as to prevent the oil barrels from damaging.
3. Mechanical performance: it's equipped with sideshifting function inside, which can realize the clamping/opening and sideshifting functions simultaneously, which is convenient for the placement of oil barrels and has good view; and it can meet the use requirements by adding two groups of oil lines.

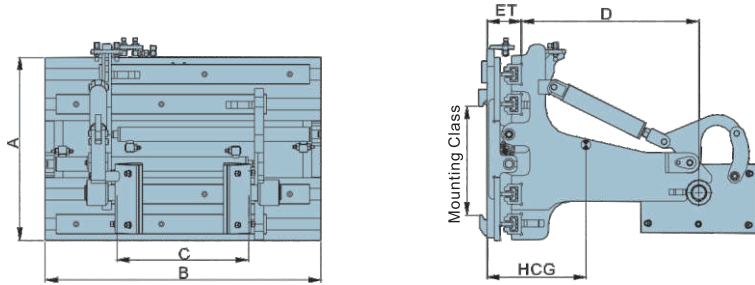

Capacity@ Load Center (Kg@mm)	Catalog Order No.	Mounting Class	Opening Range (mm)	Overall Height A (mm)	Overall Width B (mm)	Forward Rotation Angle (°)	Weight (kg)	Effective Thickness ET (mm)	Horizontal Center of Gravity HCG (mm)	Available Forklift (t)
300@630	<b>DT03G-A1</b>	II	432~1612	640	970	180	350	120	210	1-2.5t

Notes: 1. Please gain the actual overall carrying capacity of forklift trucks/attachments from the forklift truck manufacturers.  
2. Forklift truck needs to add two groups of additional oil lines so as to match the attachments.



Model	Pressure Value Bar		Flow Value L/min				
	Max.	Min. Recommend	Sideshift action		Clamping action		
			Min.	Max.	Min.	Max.	
<b>DT03G-A1</b>	160	4	7.5	11	19	26	38

### Configuration of Key Parts of Truck Attachments

1. Hydraulic system: all the seals adopt imported products; and the high-pressure rubber hoses adopt cone sealed high-performance imported rubber hoses.
2. Structural part: the guide rail assembly is welded by high-performance alloy steel plates, which has good anti-bending performance.
3. Mechanical performance: it has the tipping function, it can realize the clamping/opening and tipping actions simultaneously, which has better view; and it can meet the use requirements by adding two groups of oil lines.
4. Applicable scope: it's applied for the sites of forward tipping and emptying of cylindrical iron drum, oil drum, rubbish bin, etc..

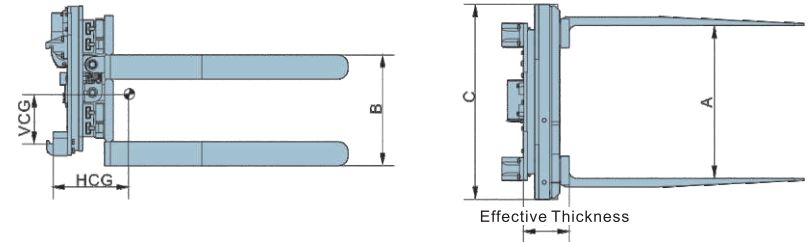

Capacity@ Load Center (Kg@mm)	Catalog Order No.	Mounting Class	Opening Range A (mm)	Tire Size (mm)	Tire Spacing B (mm)	Effective Thickness ET (mm)	Vertical Center of Gravity VCG (mm)	Horizontal Center of Gravity HCG (mm)	Weight (kg)	Available Forklift (t)
1000@685	<b>XC10G-A1</b>	II	390-1390	45x150x1370	800	313	328	386	875	2-2.5t
1500@610	<b>XC15G-B1</b>	III	1020-2330	45x125x1220	940	307	335	288	875	3-4.5t
2300@610	<b>XC23G-B1</b>	III	710-2020	45x125x1220	575	313	295	297	825	3-4.5t

Notes: 1. Please gain the actual overall carrying capacity of forklift trucks/attachments from the forklift truck manufacturers.  
2. Forklift truck needs to add two groups of additional oil lines so as to match the attachments.

Model	Pressure Value Bar		Flow Value L/min				
	Max.	Min. Recommend	Rotating action		Clamping action		
			Min.	Max.	Min.	Max.	
<b>XC**G</b>	160	19	38	57	26	38	40

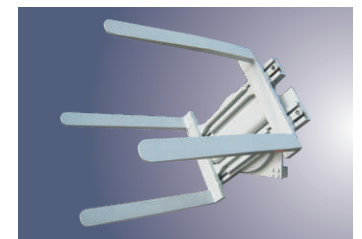

### Configuration of Key Parts of Truck Attachments

1. Hydraulic system: all motors and other key hydraulic components adopt originally imported hydraulic products; all the seals adopt imported products; and the high-pressure rubber hoses adopt cone sealed high-performance imported rubber hoses.
2. Structural part: it adopts large-modulus slewing bearing, which has stronger bearing capacity. The turbine and worm adopts involute gears, so as to not only increase the efficiency and decrease the heat loss, but also realized the self-locking function.
3. Mechanical performance: it can realize the 360° rotation, and it adopts two-way hydraulic locks for rotating oil lines so as to realize two-way self-locking and ensure the safety at work. And it adds hydraulic control check valve for each oil cylinder to realize holding pressure for a long time.
4. Applicable scope: it has the clamp rotating and handling functions, which can be used in the handling and sorting operations of carton and bale cargoes.

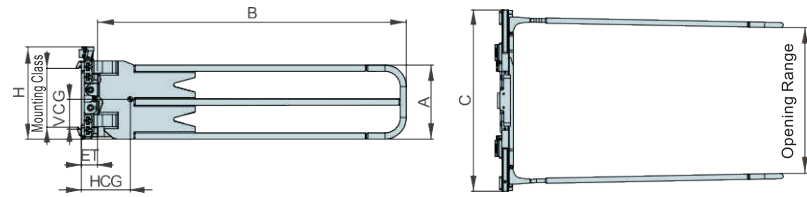

Capacity@ Load Center (Kg@mm)	Catalog Order No.	Mounting Class	Frame Width (mm)	Opening Range (mm)	Arm Height A (mm)	Arm Length B (mm)	Overall Height H (mm)	Weight (kg)	Effective Thickness ET (mm)	Horizontal Center of Gravity HCG (mm)	Available Forklift (t)	Vertical Center of Gravity VCG (mm)
500@1000	<b>HX05G-B1</b>	III	1680	1270-3120	600	1825	750	890	134	429	3-4.5t	244
1500@500	<b>HX15G-B2</b>	III	1680	650-2510	600	1825	750	800	134	410	3-4.5t	242
2200@500	<b>HX22G-B1</b>	III	1680	740-2590	600	2525	750	880	134	546	3.5-4.5t	242
1000@1000	<b>HX10G-B1</b>	III	1680	730-2580	600	2825	750	910	134	619	3-4.5t	242
1000@500	<b>HX10G-B2</b>	III	1100	885-2310	600	1505	738	740	134	369	3-4.5t	251

- Notes: 1. Please gain the actual overall carrying capacity of forklift trucks/attachments from the forklift truck manufacturers.  
2. Forklift truck needs to add two groups of additional oil lines so as to match the attachments.

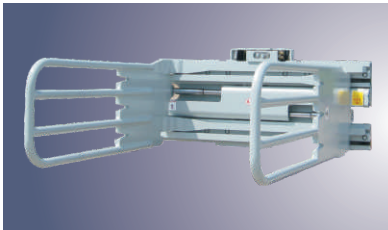

Model	Pressure Value Bar			Flow Value L/min		
	Sideshift action			Clamping action		
	Max.	Min.	Recommd	Max.	Min.	Recommd
<b>HX**G</b>	160	4	23	38	15	38

### Configuration of Key Parts of Truck Attachments

- Hydraulic system: the load keeping valves of the main control valves adopt originally imported products; all the seals adopt imported products; and the high-pressure rubber hoses adopt cone sealed high-performance imported rubber hoses.
- Structural part: the guide rail assembly is welded by high-performance alloy steel plates, which has good anti-bending performance.
- Mechanical performance: it's equipped with sideshifting function inside, which can realize the clamping/opening and sideshifting functions simultaneously with good view; and it can meet the use requirements by adding two groups of oil lines.
- Applicable scope: it's applied to the handling and stacking operations of compressed sponge and rubber.

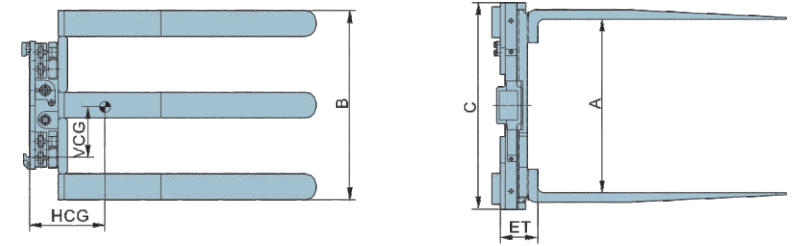

Capacity@ Load Center (Kg@mm)	Catalog Order No.	Mounting Class	Opening Range A (mm)	Frame Width C (mm)	Time Spacing B (mm)	Effective Thickness ET (mm)	Vertical Center of Gravity VCG (mm)	Horizontal Center of Gravity HCG (mm)	Weight (kg)	Available Forklift (t)
2700@500	<b>FC30G-B1</b>	III	710-2020	1010	45x125x1220	925	183	310	302	655 3-4.5t

- Notes: 1. Please gain the actual overall carrying capacity of forklift trucks/attachments from the forklift truck manufacturers.  
2. Forklift truck needs to add two groups of additional oil lines so as to match the attachments.

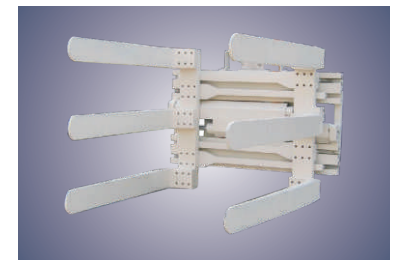

Model	Pressure Value Bar			Flow Value L/min		
	Sideshift action			Clamping action		
	Max.	Min.	Recommd	Max.	Min.	Recommd
<b>FC**G</b>	160	4	23	40	15	38

### Configuration of Key Parts of Truck Attachments

- Hydraulic system: the load keeping valves of the main control valves adopt originally imported products; all the seals adopt imported products; and the high-pressure rubber hoses adopt cone sealed high-performance rubber hoses.
- Structural part: the clamp arms adopt alloy steel castings, and the guide rail assembly is welded by high-performance alloy steel plates, which has good anti-bending performance.
- Mechanical performance: it's equipped with sideshifting function inside, which can realize the clamping/opening and sideshifting actions simultaneously with good view; and it can meet the use requirements by adding two groups of oil lines.
- Applicable scope: it has the clamping and handling functions, and it's applied to the handling and sorting operations of waste paper, carton and bale cargoes.

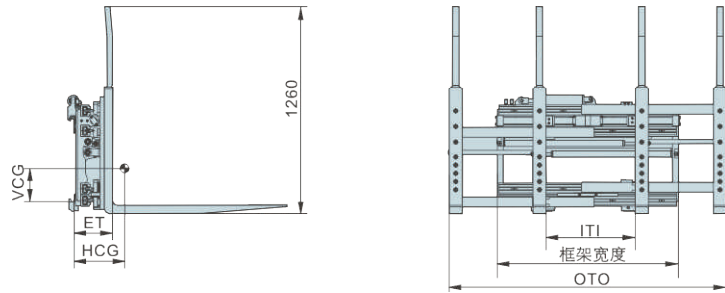

Capacity@ Load Center (Kg@mm)	Catalog Order No.	Mounting Class	Frame Width (mm)	Opening Range III (mm)	Opening Range OTO (mm)	Fork Size Fork LengthX Section (mm)	Total Side Shift (mm)	Backrest Height (mm)	Weight (kg)	Effective Thickness ET (mm)	Horizontal Center of Gravity HCG (mm)	Available Forklift (t)
2800@600	<b>DS28G-B1</b>	III	1100	371-729	705-2100	1065X80X50	±100	1260	550	236	224	3-4.5t
2800@600	<b>DS28G-A1</b>	II	1100	371-729	705-2100	1065X80X50	±100	1260	550	246	224	1-2.5t

- Notes: 1. Please gain the actual overall carrying capacity of forklift trucks/attachments from the forklift truck manufacturers.  
2. Forklift truck needs to add two groups of additional oil lines so as to match the attachments.

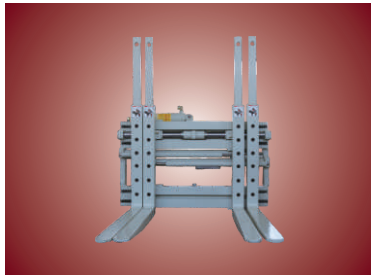

Model	Pressure Value Bar		Flow Value L/min				
	Sideshift action		Clamping action				
	Max.	Min. Recommend	Max.	Min. Recommend	Max.		
<b>DS**G</b>	160	4	23	38	15	38	38

### Configuration of Key Parts of Truck Attachments

1. Hydraulic system: the load keeping valves of the main control valves adopt originally imported products; all the seals adopt imported products; and the high-pressure rubber hoses adopt cone sealed high-performance rubber hoses.
2. Structural part: the forks adopt alloy steel castings, and the guide rail assembly is welded by high-performance alloy steel plates, which has good anti-bending performance.
3. Mechanical performance: it's equipped with sideshifting function inside, which can realize the clamping/opening and sideshifting actions simultaneously with good view; and it can meet the use requirements by adding two groups of oil lines.
4. Applicable scope: the two pairs of forks are driven by the hydraulic pressure to act quickly, and they can handle two pallets at one time while being separated, and they can operate flexibly as common forklift trucks while being closed, and they are specially suitable for stacking the cargoes (such as beer pallets) in containers during handling.

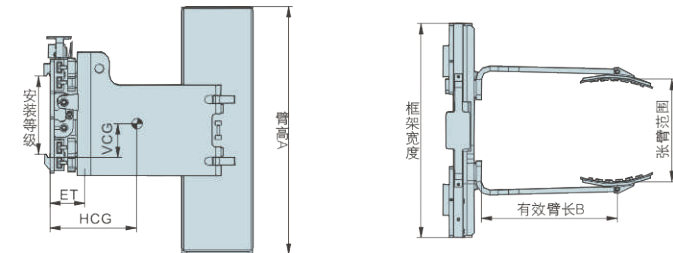

Capacity@ Load Center (Kg@mm)	Catalog Order No.	Truck Mounting Class	Clamping Range (mm)	Opening Range (mm)	Arm Height A (mm)	Arm Length (mm)	Frame Width (mm)	Weight (kg)	Effective Thickness ET (mm)	Vertical Center of Gravity VCG (mm)	Horizontal Center of Gravity HCG (mm)	Available Forklift (t)
1000@680	<b>LT10G-A1</b>	II	580-1360	500-1680	1200	680	1040	540	122	184	331	1-2.5t
1000@800	<b>LT10G-B1</b>	III	580-1600	500-1680	1500	800	1040	625	127	230	399	3-4.5t

- Notes: 1. Please gain the actual overall carrying capacity of forklift trucks/attachments from the forklift truck manufacturers.  
2. Forklift truck needs to add two groups of additional oil lines so as to match the attachments.  
3. The arm thickness is the needed minimum wedge gap size when clamping, but not the real thickness.



Model	Pressure Value Bar		Flow Value L/min		
	Sideshift action		Clamping action		
	Min.	Max.	Min.	Recommend	Max.
<b>LT**G</b>	35	160	19	26	38

### Configuration of Key Parts of Truck Attachments

1. Hydraulic system: the load keeping valves of the main control valves adopt originally imported products; all the seals adopt imported products; and the high-pressure rubber hoses adopt cone sealed high-performance imported rubber hoses.
2. Structural part: it adopts the micro adjustable combined clamp arm structure, and the left and right clamping panels adopt high-performance alloy steel plates, and the root of clamp arms adopt the process of integral hot press, which has reliable performance.
3. Mechanical performance: it can realize the clamping/opening and sideshifting functions simultaneously, with simple operation and good view.



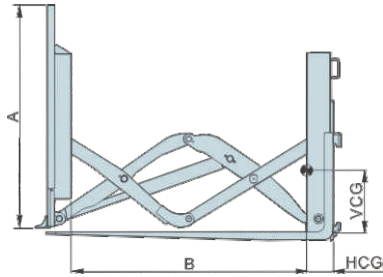

Capacity@ Load Center (Kg@mm)	Catalog Order No.	Mounting Class	Push Range B (mm)	Baffle Height x Width (mm)	Weight (Kg)	Effective Thickness ET (mm)	Vertical Center of Gravity VCG (mm)	Horizontal Center of Gravity HCG (mm)	Available Forklift (t)
1000@500	<b>TL10J-A1</b>	II	1200	1130 × 1100	360	255	430	136	1-2.5t
1000@500	<b>TL10J-A2</b>	II	920	890 × 976	330	255	391	133	1-2.5t
2000@500	<b>TL20J-B11</b>	III	1200	1800 × 1400	410	255	515	148	3-4.5t
2000@500	<b>TL20J-B13</b>	III	1200	1010 × 1100	360	305	420	135	3-4.5t
2000@500	<b>TL20J-B14</b>	III	1200	1550 × 1400	400	305	477	145	3-4.5t

Notes: 1. Please gain the actual overall carrying capacity of forklift trucks/attachments from the forklift truck manufacturers.  
2. Forklift truck needs to add two groups of additional oil lines so as to match the attachments.

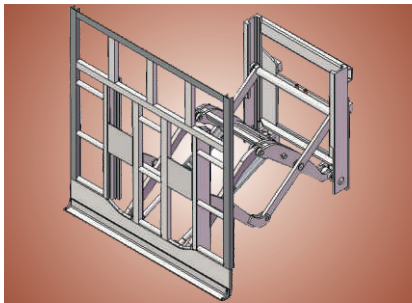

Model	Pressure Value Bar		Flow Value L/min	
	Max.	Min.	Recommend	Max.
<b>TL**J</b>	160	15	26	38

### Configuration of Key Parts of Truck Attachments

1. Hydraulic system: the push oil cylinders adopt piston cylinders, which are simple in structure and convenient for processing and repairing; all the seals adopt NOK series products, which have reliable quality.
2. Structural part: the push arms adopt high-strength plates, and the raceways adopt German imported materials, which are enough to meet the use requirements; and the under hooks are adjustable, convenient for installation and reliable in quality.
3. Mechanical performance: the oil cylinders and frames are laid out rationally and it has safe and reliable performance.
4. Applicable scope: this kind of pushes is applied to the transportation of cement, fertilizer, grain and other bag goods.

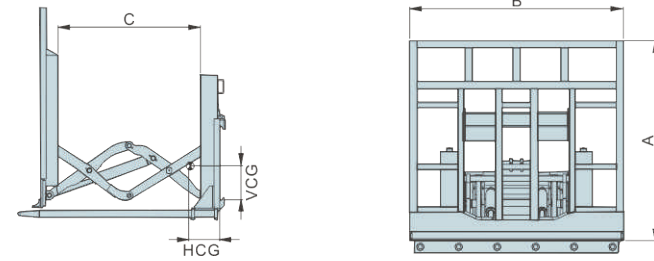

Capacity@ Load Center (Kg@mm)	Catalog Order No.	Mounting Class	Push Range C (mm)	Fork Length (mm)	Baffle Height x Width (mm)	Weight (kg)	Effective Thickness ET (mm)	Horizontal Center of Gravity HCG (mm)	The Amount @line Spacing	Available Forklift (t)
1000@500	<b>TL10C-A8</b>	II	1200	1165	1600 × 1400	720	255	295	8@193	1-2.5t
1000@500	<b>TL10C-A10</b>	II	1200	1400	1510 × 1600	730	255	330	8@215	1-2.5t
1000@500	<b>TL10C-A11</b>	II	1000	1000	1200 × 1100	556	255	223	6@200	1-2.5t
2000@500	<b>TL20C-B2</b>	III	900	910	1600 × 1200	565	255	215	6@224	3-4.5t
2000@500	<b>TL20C-B5</b>	III	1200	1165	1800 × 1400	650	255	210	6@270	3-4.5t
2000@500	<b>TL20C-B6</b>	III	1400	1355	1550 × 1400	695	255	273	6@238	3-4.5t
2000@500	<b>TL20C-B7</b>	III	900	910	1415 × 1200	530	255	210	6@200	3-4.5t
2000@500	<b>TL20C-B8</b>	III	1000	1000	1400 × 1500	620	255	240	6@274	3-4.5t
2000@500	<b>TL20C-B9</b>	III	900	910	1800 × 1500	650	255	340	10@161	3-4.5t
2000@500	<b>TL20C-B10</b>	III	1200	1225	1515 × 1500	730	255	302	9@170	3-4.5t
2000@500	<b>TL20C-B15</b>	III	1200	1225	1600 × 1450	645	255	230	6@291	3-4.5t
2000@500	<b>TL20C-B16</b>	III	1200	1165	1500 × 1400	640	255	238	6@238	3-4.5t

Notes: 1. Please gain the actual overall carrying capacity of forklift trucks/attachments from the forklift truck manufacturers.  
2. Forklift truck needs to add two groups of additional oil lines so as to match the attachments.  
3. The forks adopt round rod forks.

Model	Pressure Value Bar		Flow Value L/min	
	Max.	Min.	Recommend	Max.
<b>TL**C</b>	160	15	26	38



### Configuration of Key Parts of Truck Attachments

1. Hydraulic system: the push oil cylinders adopt piston cylinders, which are simple in structure and convenient for processing and repairing; all the seals adopt NOK series products, which have reliable quality.
2. Structural part: the push arms adopt high-strength plates, which are good enough to meet the use requirements; and the under hooks are adjustable, convenient for installation and reliable in quality.
3. Mechanical performance: the oil cylinders and frames are laid out rationally and have safe and reliable performance.
4. Applicable scope: this kind of pushes is applied to the transportation of cement, fertilizer, grain and other bag goods.

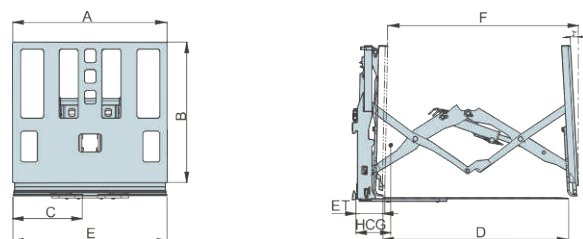

Capacity@ Load Center (Kg@mm)	Catalog Order No.	Mounting Class	Push Range F (mm)	Baffle Height x Width BxA (mm)	Weight (kg)	Effective Thickness ET (mm)	Platen Height x Width DxC (mm)	Outside Platen Spacing E (mm)	Horizontal Center of Gravity HCG (mm)	Available Forklift (t)
1600@500	<b>TL16L-A1</b>	II	1230	920×1014	360	190	1200×455	1012	270	1-2.5t
1600@500	<b>TL16L-A2</b>	II	1230	920×1014	435	275	1285×455	1012	296	1-2.5t
2000@500	<b>TL20L-B1</b>	III	1230	920×1014	410	215	1200×455	1012	293	3-4.5t
2000@500	<b>TL20L-B2</b>	III	1230	920×1014	495	295	1200×455	1012	300	3-4.5t

- Notes: 1. Please gain the actual overall carrying capacity of forklift trucks/attachments from the forklift truck manufacturers.  
 2. Forklift truck needs to add a group of additional oil lines.  
 3. The standard forks equipped for the quick-installed push/pulls shall be purchased otherwise.  
 4. TL20L-B1 push/pulls need to choose the forks with thickness of 45.  
 5. TL16L-A2 and TL20L-B2 is the slide board stay-type push/pulls.



Model	Pressure Value Bar		Flow Value L/min	
	Max.	Min.	Recommend	Max.
<b>TL**L</b>	160	15	26	38

### Configuration of Key Parts of Truck Attachments

1. Hydraulic system: the push oil cylinders adopt piston cylinders, which are simple in structure; all the seals adopt imported products; the overflow valves adopt originally imported valve cores with reliable quality; and the rubber pipes adopt high-strength imported rubber pipes.
2. Structural part: the fork plates and connection plates adopt high-strength plates, which can meet the use requirements.
3. Mechanical performance: it controls the two groups of oil cylinders by overflow valves so as to realize pushing and pulling cargoes, and it has good view.

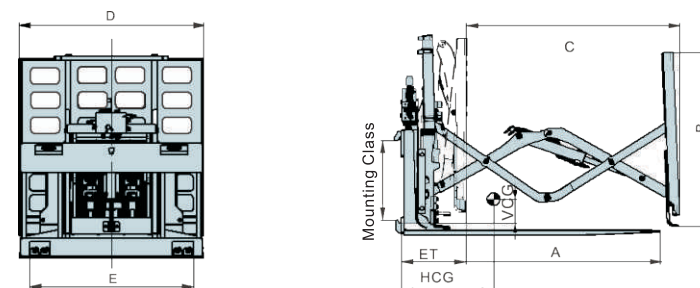

Capacity@ Load Center (Kg@mm)	Catalog Order No.	Mounting Class	Push Range C (mm)	Baffle Height x Width BxA (mm)	Weight (kg)	Effective Thickness ET (mm)	A (mm)	Horizontal Center of Gravity HCG (mm)	Horizontal Center of Gravity VCG (mm)	Minimum Truck Carriage Width
1600@500	<b>TL16B-A4</b>	II	1230	986×1014	615	305	1160	296	195	940
1600@600	<b>TL16B-B2</b>	III	1350	1050×1014	670	305	1250	360	205	900
1600@500	<b>TL16B-B4</b>	III	1230	1200×1200	750	305	1170	300	205	950

- Notes: 1. Please gain the actual overall carrying capacity of forklift trucks/attachments from the forklift truck manufacturers.  
 2. Forklift truck needs to add two groups of additional oil lines so as to match the attachments.

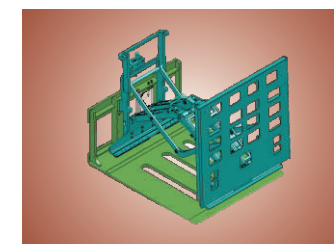

Model	Pressure Value Bar		Flow Value L/min	
	Max.	Min.	Recommend	Max.
<b>TL**B</b>	160	15	26	26

### Configuration of Key Parts of Truck Attachments

1. Hydraulic system: The introduction of the cylinder is in the form of a piston rod, and the structure is simple; the seals are all imported products; the sequential control valve adopts the original imported valve core, and the quality is reliable; the hose adopts high-strength imported hose.
2. Structural part: The mounting control valve is used to control the related actions between the three groups of cylinders, so as to realize the back and forth, the ejection of the goods, and the indwelling action of the sliding tray, and the visual field is good.
3. Mechanical performance: The fork plate is made of 30mm thick high-strength plate, which has good strength and can meet the requirements of use.

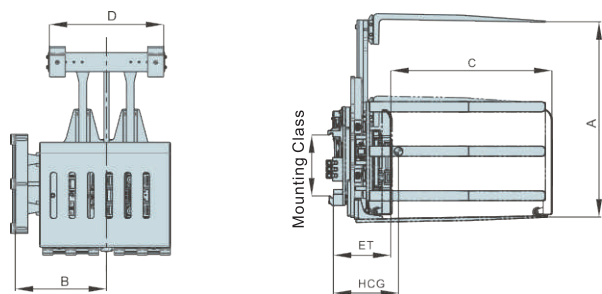

Capacity@ Load Center (Kg@mm)	Catalog Order No.	Mounting Class	Clamping Range A (mm)	Adjustment Range B (mm)	Push Range C (mm)	Weight (kg)	Effective Thickness ET (mm)	Horizontal Center of Gravity HCG (mm)	Tine Spacing D (mm)	Available Forklift (t)
1500@600	<b>XT15G-B1</b>	III	900-1500	550-700	1270	1295	460	510	505, 635, 785, 895	3-4.5t
1500@600	<b>XT15G-B2</b>	III	1150-1950	550-700	1270	1475	460	510	505, 635, 785, 895	3-4.5t

- Notes: 1. Please gain the actual overall carrying capacity of forklift trucks/attachments from the forklift truck manufacturers.  
 2. Forklift truck needs to add a group of additional oil lines to match the attachments.  
 3. Fork spacing D is adjustable.



Model	Rotating speed	Torque
<b>XT**G</b>	3.6r/min@39L/min	9000N • m@160Bar

Model	Pressure Value Bar			Flow Value L/min			Clamping action			
	Max.	Min.	Recommend	Max.	Min.	Recommend				
<b>XT**G</b>	160	15	26	38	19	38	57	15	38	40

### Configuration of Key Parts of Truck Attachments

- Hydraulic system: all oil motors, valves and other key hydraulic components adopt originally imported hydraulic products; all the seals adopt NOK imported products; and the high-pressure rubber hoses adopt cone sealed high-performance rubber hoses, which have safe and reliable quality.
- Structural part: it adopts large-modulus slewing bearing, which has stronger bearing capacity; turbine and worm adopts involute gears, so as to not only increase the efficiency and decrease the heat loss, but also realize the self-locking function.
- Key part: it's welded by high-strength plates, which has safe and reliable structural strength.
- Mechanical performance: it can realize push/pull, clamping/opening and 360°two-way rotation functions, and the product is designed to have electro-hydraulic directional control valve, and it can meet the use requirements just by adding a group of oil lines
- Applicable scope: it can fork-take and handle the bag cargoes placed on the pallets safely and efficiently, and rotate 180°to push the bag cargoes to the specified position, and then recover the | pallets, it's widely used in chemical, food, packaging, logistics industries, etc..

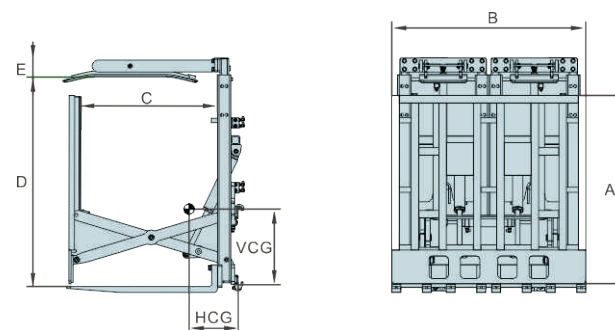

Capacity@ Load Center (Kg@mm)	Catalog Order No.	Mounting Class	Push Range C (mm)	Fork length (mm)	Baffle height x width AxB (mm)	Lift range D (mm)	Laminate Thickness E (mm)	Weight (kg)	Effective Thickness ET (mm)	Horizontal Center of Gravity HCG (mm)	Available Forklift (t)
2000@500	<b>TW20G-A1</b>	II	900	840	1260x1300	1400-2000	113	850	210	270	1-2.5t
2000@600	<b>TW20G-B1</b>	III	1200	1200	1200x1300	900-1300	151	875	315	330	3-4.5t
2000@500	<b>TW20G-B3</b>	III	900	840	1260x1300	1400-2000	113	855	210	270	3-4.5t

- Notes: 1. Please gain the actual overall carrying capacity of forklift trucks/attachments from the forklift truck manufacturers.  
 2. Forklift truck needs to add a group of additional oil lines to match the attachments.

Model	Pressure Value Bar			Flow Value L/min			Clamping action	
	Min.	Max.	Recommend	Min.	Recommend	Max.		
<b>TW**G</b>	35	160	15	26	57	19	30	38

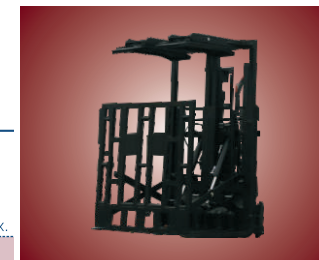

### Configuration of Key Parts of Truck Attachments

- Hydraulic system: all oil motors, valves and other key hydraulic components adopt originally imported hydraulic products; all the seals adopt NOK imported products; and the high-pressure rubber hoses adopt cone sealed high-performance rubber hoses, which have safe and reliable quality.
- Structural part: it adopts large-modulus slewing bearing, which has stronger bearing capacity; turbine and worm adopts involute gears, so as to not only increase the efficiency and decrease the heat loss, but also realize the self-locking function.
- Key part: it's welded by high-strength plates, which has safe and reliable structural strength.
- Mechanical performance: it can realize push/pull, clamping/opening and 360°two-way rotation functions, and the product is designed to have electro-hydraulic directional control valve, and it can meet the use requirements just by adding a group of oil lines
- Applicable scope: it can fork-take and handle the bag cargoes placed on the pallets safely and efficiently, and rotate 180°to push the bag cargoes to the specified position, and then recover the | pallets, it's widely used in chemical, food, packaging, logistics industries, etc..

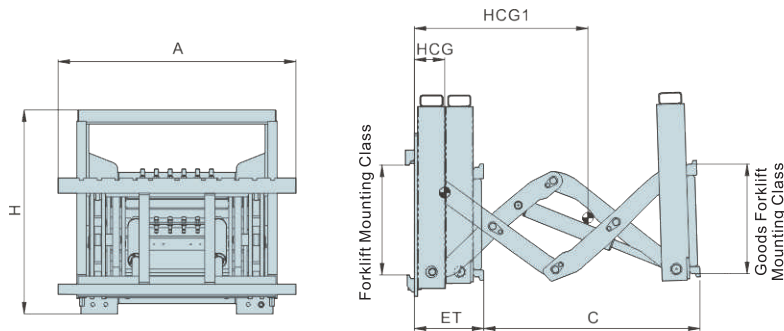

Capacity@ Load Center	Catalog Order No.	Mounting Class	Push Range	Weight	Effective Thickness	Horizontal Center of Gravity		Overall Height	Carriage Width	Available Forklift
(Kg@mm)			C (mm)	(kg)	ET (mm)	HCG (mm)	HCG1 (mm)	H (mm)	A (mm)	(t)
2000@600	<b>QJ20G-B1</b>	III/III	1000	385	302	140	595	875	1038	3-4.5t

- Notes:
- The load capacity of the load extender shall be smaller than the overall carrying capacity of forklift trucks/ attachments, and please gain the actual overall carrying capacity of forklift trucks/ attachments from the forklift truck manufacturers.
  - Forklift truck needs to add a group of additional oil lines to match the attachments.
  - It can add forks according to the needs of users, and please pay attention to the carrying capacity of the forks themselves.
  - If it needs to match other forklift truck attachments (such as paper roll clamps, bale clamps, etc.) before the load extender, please contact Anqing Liandong Engineering Trucks Attachments Co., Ltd.



Model	Pressure Value Bar		Flow Value L/min	
	Max.	Min.	Recommend	Max.
<b>QJ**G</b>	160	15	38	40

#### Configuration of Key Parts of Truck Attachments

- Hydraulic system: all the seals adopt NOK imported products; and the high-pressure rubber hoses adopt cone sealed high-performance imported rubber hoses, so as to ensure the safety and reliability of the hydraulic system.
- Structural part: all the key parts are welded by high-strength plates, and the guide rails adopt German imported channel steels, which have safe and reliable structural strength.
- Mechanical performance: it can push under loading, and realize the forward and backward of fork carriage, and have good view; and it can match other forklift truck attachments (such as paper roll clamps, bale clamps, etc.).
- Applicable scope: it can carry the cargoes placed out of the forklift truck working area safely and efficiently, and it's especially suitable for loading and unloading cargoes in the train.

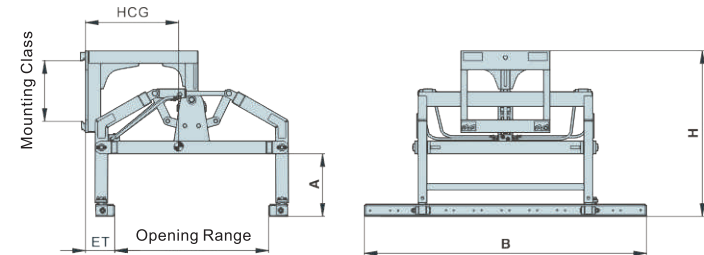

Capacity@ Load Center	Catalog Order No.	Mounting Class	Opening Range	Weight	Effective Thickness	Horizontal Center of Gravity	Arm Height	Overall Height	Slip Width	Available Forklift
(Kg@mm)			(mm)	(kg)	ET (mm)	HCG (mm)	A (mm)	H (mm)	B	(t)
1500@600	<b>ZK15D-B1</b>	III	1100-1300	855	250	735	490	1305	2200	3-4.5t
1500@600	<b>ZK15D-B2</b>	III	1100-1500	930	345	805	1150	2050	1400	3-4.5t
1500@600	<b>ZK15D-B3</b>	III	515-1000	1030	452	715	1300	2120	2000	3-4.5t
2500@600	<b>ZK25D-B1</b>	III	515-915	950	452	712	1300	2120	1700	4-4.5t

- Notes:
- Please gain the actual overall carrying capacity of forklift trucks/ attachments from the forklift truck manufacturers.
  - Forklift truck needs to add a group of additional oil lines to match the attachments.



Model	Pressure Value Bar		Flow Value L/min	
	Max.	Min.	Recommend	Max.
<b>ZK**D</b>	160	15	38	40

#### Configuration of Key Parts of Truck Attachments

- Hydraulic system: it's designed to have overflow valves for the hydraulic system, and it can adjust the clamping force according to different blocks so as to avoid to damage the blocks; and it's designed to have hydraulic control check valves for oil cylinders, so as to realize holding pressure for a long time, which have high safety; all the seals adopt NOK imported products; and the high-pressure rubber hoses adopt cone sealed high-performance imported rubber hoses, so as to ensure the safety and reliability of the hydraulic system.
- Structural part: all the key parts are welded by high-strength rectangular pipes, which have safer and more reliable structural strength.
- Mechanical performance: it adopts advanced damping technology, so there is small shake during the carrying process, and it has wide view and safe & reliable mechanical performance.
- Applicable scope: it can realize the carrying and stacking operations of blocks safely and efficiently, and it's especially suitable for carrying and palletizing aerated blocks.

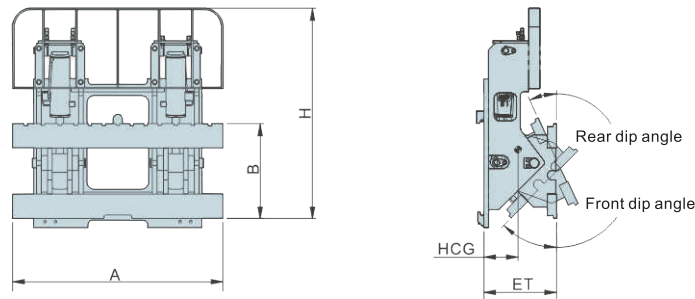

Capacity@ Load Center (Kg@mm)	Catalog Order No.	Forklift Installation grade	The goods fork installation level	Cylinder number	Beam width <b>A</b> (mm)	Beam height <b>B</b> (mm)	Total height <b>H</b> (mm)	Overall Height (kg)	Loss of load <b>ET</b> (mm)	Front dip angle/ Rear dip angle	Horizontal center of gravity <b>HCG</b> (mm)	Available Forklift (t)
3000@500	QF30J-B1	III	III	double	1100	506	1190	310	335	45°/20°	153	3-4.5t
2000@500	QF20F-A3-01	II	II	double	1100	407	1123	251	335	45°/20°	165	1-2.5t

- Notes: 1. Please gain the actual overall carrying capacity of forklift trucks/attachments from the forklift truck manufacturers.  
 2. Forklift truck needs to add a group of oil lines.  
 3. The tilting oil cylinders have no self-locking functions.  
 4. It can be equipped with various models of tipping scoops according to the needs of users.



Model	Pressure Value Bar		Flow Value L/min		
	Max.	Max.	Min.	Recommend	Max.
QF**F	35	160	19	38	57

### Configuration of Key Parts of Truck Attachments

1. Hydraulic system: all the seals adopt NOK imported products; and the high-pressure rubber hoses adopt cone sealed high-performance imported rubber hoses, so as to ensure the safety and reliability of the hydraulic system.
2. Structural part: the fork carriages are welded by high-performance alloy steel plates; the beam adopts shape steel, which has high strength.
3. Mechanical performance: it can realize 45° forward tilting and 20° backward tilting and tip cargoes easily.
4. Applicable scope: it can forward tipping the bulk cargoes in containers safely and efficiently; and if equipped with shovel, which can scrape various loose cargoes, such as sand, coal, grain, fertilizer, clod and broken bricks, etc..

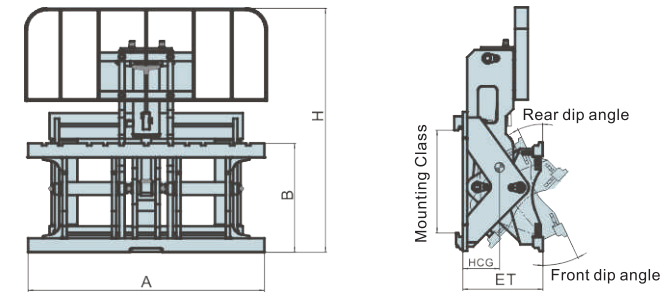

Capacity@ Load Center (Kg@mm)	Catalog Order No.	Truck Mounting Class	Hinged Fork Mounting Class	Cylinder Quantity	Carriage Width <b>A</b> (mm)	Carriage Height <b>B</b> (mm)	Overall Height <b>H</b> (mm)	Weight (Kg)	Effective Thickness <b>ET</b> (mm)	Tilt Forward Tilt Backward	Horizontal Center of Gravity <b>HCG</b> (mm)	Available Forklift (t)
2000@500	QF20F-A1	II	III	single	1100	506	1132	315	375	45°/25°	165	1-2.5t
2000@500	QF20F-A2	II	II	single	1040	407	1132	295	375	45°/25°	165	1-2.5t
3000@500	QF30F-B1	III	III	single	1100	506	1132	305	375	45°/25°	165	3-4.5t
3000@500	QF30F-B3	III	III	single	1300	506	1132	325	375	45°/25°	183	3-4.5t

- Notes: 1. Please gain the actual overall carrying capacity of forklift trucks/attachments from the forklift truck manufacturers.  
 2. Forklift truck needs to add a group of additional oil lines to match the attachments, all the oil cylinders have self-locking functions.  
 3. It can be equipped with various models of tipping (shovel) scoops according to the needs of users.

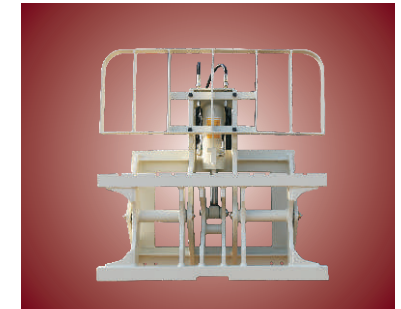

Model	Pressure Value Bar		Flow Value L/min		
	Max.	Max.	Min.	Recommend	Max.
QF**F	35	160	19	38	57

### Configuration of Key Parts of Truck Attachments

1. Hydraulic system: the oil cylinders adopt originally imported hydraulic control check valves; all the seals adopt imported products; and the high-pressure rubber hoses adopt cone sealed high-performance imported rubber hoses.
2. Structural part: the fork carriages are welded by high-performance alloy steel plates.
3. Mechanical performance: it can realize 45° forward tilting and 25° backward tilting, and it adds hydraulic control check valves for the oil cylinders to realize holding pressure for a long time, and further ensure the safety at work or rubber hoses burst.
4. Applicable scope: it can forward tipping the bulk cargoes in containers safely and efficiently; and it's equipped with shovel, which can scrape various loose cargoes, such as sand, coal, grain, fertilizer, clod and broken bricks, etc..

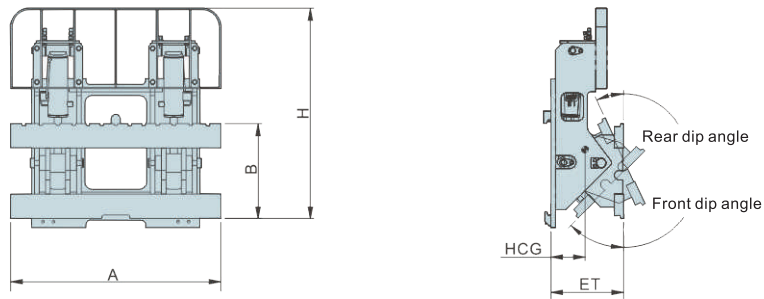

Capacity@ Load Center (Kg@mm)	Catalog Order No.	Truck Mounting Class	Hinged Fork Mounting Class	Cylinder Quantity	Carrige Width A (mm)	Carrige Height B (mm)	Overall Height H (mm)	Weight (kg)	Effective Thickness ET (mm)	Tilt Forward Tilt Backward 45°/25°	Horizontal Center of Gravity HCG (mm)	Available Forklift (t)
3500@500	QF35F-B1-02	III	III	double	1100	506	1172	360	392	45°/25°	165	3-4.5t
4500@600	QF45F-B1-01	III	III	double	1800	506	1172	680	392	45°/25°	193	3-4.5t
4500@600	QF45F-B2-01	III	III	double	1126	506	1172	510	392	45°/25°	132	3-4.5t
4500@600	QF45F-B3-01	III	III	double	1500	506	1172	670	392	45°/25°	190	3-4.5t
5000@600	QF50F-C1-01	IV	III	double	1800	506	1172	690	392	45°/25°	193	5-7t
5000@600	QF50F-C2-01	IV	IV	double	1785	634	1210	785	427	45°/25°	210	5-7t

- Notes: 1. Please gain the actual overall carrying capacity of forklift trucks/attachments from the forklift truck manufacturers.  
 2. Forklift truck needs to add a group of additional oil lines to match the attachments, and all the oil cylinders have self-locking functions.  
 3. It can be equipped with various models of tipping (shovel) scoops according to the needs of users.

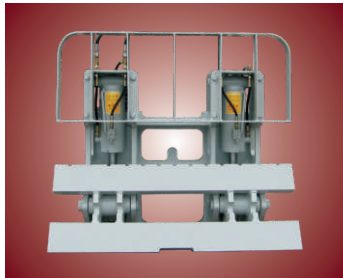

Model	Pressure Value Bar		Flow Value L/min		
	Min.	Max.	Min.	Recommend	Max.
QF**F	35	160	19	38	57

### Configuration of Key Parts of Truck Attachments

1. Hydraulic system: the oil cylinders adopt originally imported hydraulic control check valves; all the seals adopt imported products; and the high-pressure rubber hoses adopt cone sealed high-performance imported rubber hoses.
2. Structural part: the fork carriages are welded by high-performance alloy steel plates.
3. Mechanical performance: It adds hydraulic control check valves for the oil cylinders to realize holding pressure for a long time, and further ensure the safety at work or rubber hoses burst.
4. Applicable scope: it can forward tipping the bulk cargoes in containers safely and efficiently; and it's equipped with shovel, which can scrape various loose cargoes, such as sand, coal, grain, fertilizer, clod and broken bricks, etc..

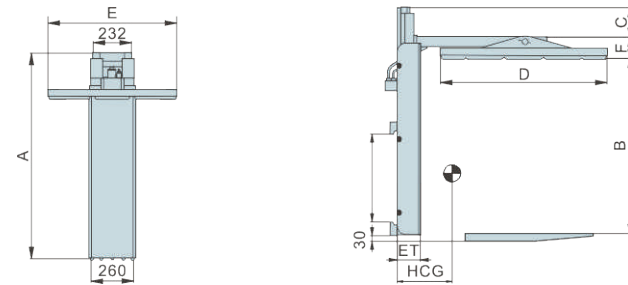

Capacity@ Load Center (Kg@mm)	Catalog Order No.	Mounting Class	Moving Range B (mm)	Overall Height A (mm)	Height C (mm)	F (mm)	Contact Pad Packing Force (bar)	Weight (kg)	Effective Thickness ET (mm)	Contact Pad Length D	Contact Pad Width E	Horizontal Center of Gravity HCG (mm)	Available Forklift (t)
2000@500	WD20J-A1	II	955-1965	1240	170	116	100-160	275	126	1100	1100	340	1-2.5t
2000@500	WD20J-A2	II	1485-2495	1770	170	116	100-160	310	126	1100	1100	320	1-2.5t
2000@500	WD20J-A3	II	1085-2095	1290	170	116	100-160	250	126	910	910	290	1-2.5t
3000@500	WD30J-A1	II	955-1965	1240	170	116	100-160	240	126	910	780	275	1-2.5t
3000@500	WD30J-A2	II	955-1965	1240	170	116	100-160	250	126	910	910	290	1-2.5t
3000@500	WD30J-B1	III	955-1965	1240	170	116	100-160	240	126	910	780	275	3-4.5t
3000@500	WD30J-B2	III	955-1965	1240	170	116	100-160	275	126	1100	1100	340	3-4.5t
3000@500	WD30J-B3	III	955-1965	1240	170	116	100-160	260	126	1000	1000	315	3-4.5t

- Notes: 1. Please gain the actual overall carrying capacity of forklift trucks/attachments from the forklift truck manufacturers.  
 2. Forklift truck needs to add a group of additional oil lines to match the attachments.  
 3. Before choosing the full free series forklift trucks, please contact with AnqingLiandong Engineering Trucks Attachments Co., Ltd. to confirm whether such model of forklift trucks can be used.

Model	Pressure Value Bar		Flow Value L/min		
	Min.	Max.	Min.	Recommend	Max.
WD**J	100	160	19	30	38



### Configuration of Key Parts of Truck Attachments

1. Hydraulic system: it's equipped with adjustable pressure control valves, and it can be adjusted according to the requirements; all the seals adopt imported products; and the high-pressure rubber hoses adopt cone sealed high-performance imported rubber hoses.
2. Structural part: main parts adopt high-strength steel plates, which are good in anti-deformation and rational in exterior design as well as simple & elegant.
3. Mechanical performance: it adjusts by oil cylinder, and it can make the adjustment of opening/clamping according to different height of cargoes, which has good view; and it can meet the use requirements by adding a group of oil lines.
4. Applicable scope: it's widely used in food, beverage, import & export trading industries, etc., and it's mainly used to stabilize the cargoes on the pallets, so as to prevent the cargoes from falling down during the carrying process due to staying too high.

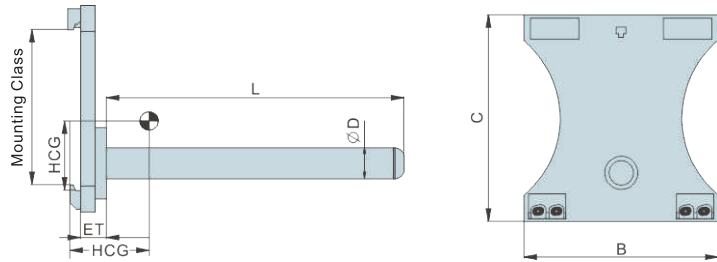

Capacity@ Load Center (Kg@mm)	Catalog Order No.	Mounting Class	Rod Diameter D	Bar Arm Length L	Weight (kg)	Effective Thickness ET (mm)	Vertical Center of Gravity VCG (mm)	Horizontal Center of Gravity HCG (mm)	Overall Width /Overall Height B/C (mm)
1000@500	CG10G-A1	II	60	1070	105	40	193	142	500/530
1000@500	CG10G-A4	II	65	1070	110	40	192	156	500/530
1000@500	CG10G-A8	II	70	1070	115	40	192	170	500/530
1000@500	CG10G-A13	II	75	2000	155	80	200	488	440/525
1000@700	CG10G-B1	III	85	1070	275	50	283	125	500/635
1000@700	CG10G-B6	III	100	1070	295	50	281	155	500/635
1500@500	CG15G-B1	III	70	1100	160	80	212	148	493/636
2000@700	CG20G-B3	III	70	1450	180	80	204	222	493/636
1500@500	CG30G-B1	III	70	1000	155	80	215	129	493/636
4500@500	CG45G-C1	IV	140	1100	400	95	326	225	680/785

Notes: Please gain the actual overall carrying capacity of forklift trucks/attachments from the forklift truck manufacturers.

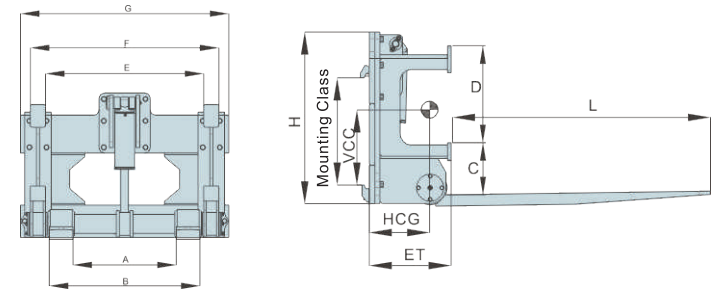

Capacity@ Load Center (Kg@mm)	Catalog Order No.	Mounting Class	Effective Thickness ET (mm)	Fork Thickness A/B (mm)	Tilt Forward Angle $\alpha$ (°)	Fork Thickness E/F (mm)	Fork Length L/T (mm)	Fork Spacing C/D (mm)	Frame Width G/H (mm)	Horizontal/ Vertical Center of Gravity HCG/VCG (mm)	Weight (kg)	Available Forklift (t)
3000@600	HW30G-B1	III	363	545/795	73°	835/995	1150/50	230/430	1100/762	312/285	420	3-4.5t
3000@600	HW30G-B2	III	363	545/795	73°	835/995	1150/50	230/478	1100/762	312/287	420	3-4.5t
3000@600	HW30G-B3	III	363	545/795	73°	680/840	1150/50	330/430	1100/762	280/173	440	3-4.5t

Notes: 1. Please gain the actual overall carrying capacity of forklift trucks/attachments from the forklift truck manufacturers.  
2. Forklift truck needs to add a group of additional oil lines to match the attachments.

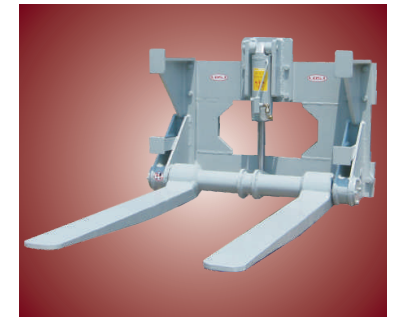

Model	Pressure Value Bar		Flow Value L/min		
	Min.	Max.	Min.	Recommend	Max.
HW**G	35	160	19	38	57

### Configuration of Key Parts of Truck Attachments

1. Hydraulic system: all the seals adopt imported products; and the high-pressure rubber hoses adopt cone sealed high-performance imported rubber hoses.
2. Structural part: the forks adopt alloy steel castings, and frame body is welded by high-performance alloy steel plated.
3. Mechanical performance: it can realize 73° forward tilting, and it adds hydraulic control check valves for the oil cylinders to realize holding pressure for a long time, and further ensure the safety at work or rubber hoses burst; and it can meet the use requirements by adding a group of oil lines.
4. Applicable scope: it's applied to the sites of forward tipping the cargoes efficiently, etc., especially the Sanitation Department, so as to save the time of manual handling and tipping.

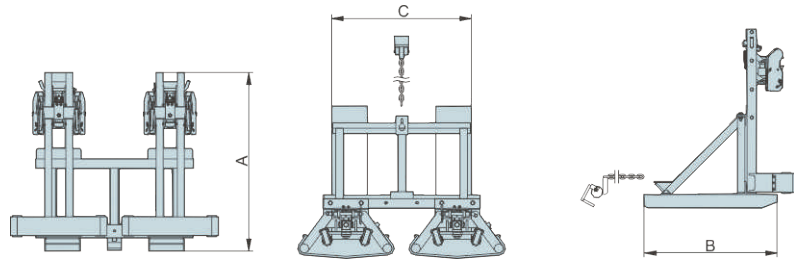

Capacity@ Load Center (Kg@mm)	Catalog Order No.	Overall Length B (mm)	Overall Height A (mm)	Weight (kg)	Frame Width C (mm)	Available Forklift (t)
900@1500	YT09G-A1	1080	960	115	840	1-10t
2000@1500	YT20G-B1	1080	980	165	840	1-10t

- Notes: 1. Please gain the actual overall carrying capacity of forklift trucks/attachments from the forklift truck manufacturers.  
 2. It can be used in conjunction with 1-1 Ot forklift trucks, which can be directly covered on the truck fork with convenient installation.  
 3. The actual load center spacing is large, and the effective load may be only about half of the actual load.

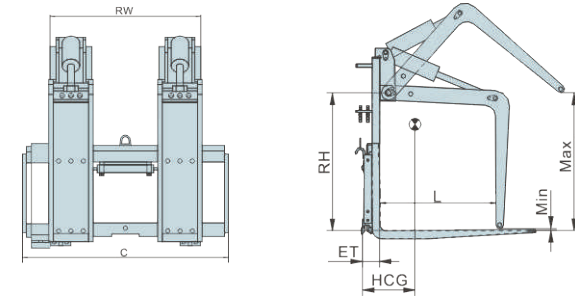

Capacity@ Load Center (Kg@mm)	Catalog Order No.	Mounting Class	Raker Width RW (mm)	Raker Pivot Height RH (mm)	Raker Pivot Height (mm)	Minimum Clip Distance L (mm)	Fork Length FL (mm)	Frame Width C (mm)	Effective Thickness ET (mm)	Horizontal Center of Gravity HCG (mm)	Weight (kg)	Available Forklift (t)
3000@600	YM30G-B1	III	1030	1105	1330/100	1075	Standard fork	1380	116	280	685	3-4.5t
4500@600	YM45G-B1	III	1000	890	935/10	775	Standard fork	1380	116	200	610	3-4.5t

- Notes: 1. Please gain the actual overall carrying capacity of forklift trucks/attachments from the forklift truck manufacturers.  
 2. Forklift truck needs to add two groups of additional oil lines so as to match the attachments.



Model	Pressure Value Bar		Flow Value L/min		
	Min.	Max.	Min.	Recommend	Max.
YM**G	35	160	19	38	57

Configuration of Key Parts of Truck Attachments

- Hydraulic system: the oil cylinders adopt originally imported hydraulic control check valves; all the seals adopt imported products; and the high-pressure rubber hoses adopt cone sealed high- performance imported rubber hoses.
- Mechanical performance: ifs equipped with sideshifting function outside, which shall be used in conjunction with external fork, so as to realize forward tilting clamp; and it adds hydraulic control check valves for the oil cylinders to realize holding pressure for a long time, and further ensure the safety at work or rubber hoses burst.
- Applicable scope: it's applied to the transportation by clamping various round pieces of wood and round clothes, etc., which reduces the logistics costs and increases the production efficiency significantly.



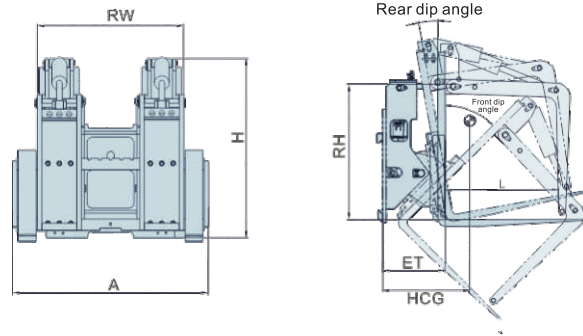

Capacity@ Load Center	Catalog Order No.	Truck Mounting Class	Hinged Fork Mounting Class	Carriage Width	Raker	Raker	Minimum	Distance	Effective	Horizontal	Tilt Forward	Tilt Backward	Weight	Available Forklift
					Width	Pivot Height	Clip Length	Thickness	Center of Gravity	Angle	Angle	(kg)		
(Kg@mm)				A (mm)	RW (mm)	RH (mm)	L (mm)	ET (mm)	HCG (mm)					
3000@500	QY30G-B1	III	Non-standard fork	1500	345	1100	970	345	350	350	50°/10°	870	3-4.5t	
5000@600	QY50G-C4	IV	Non-standard fork	1785	275	1170	970	385	350	350	45°/10°	960	5-7t	
2500@600	QY25G-B6	III	Non-standard fork	1380	345	1100	970	335	430	430	50°/10°	700	3-4.5t	
2500@500	QY25G-B7	III	Standard fork	1380	310	1090	980	380	430	430	50°/10°	545	3-4.5t	

Notes: 1. Please gain the actual overall carrying capacity of forklift trucks/attachments from the forklift truck manufacturers.  
 2. Forklift truck needs to add two groups of additional oil lines to match the attachments, and all the oil cylinders have self-locking functions.

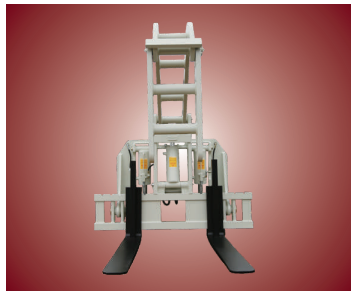

Model	Pressure Value Bar		Flow Value L/min		
	Min.	Max.	Min.	Recommend	Max.
	QY**G	35	160	19	38

Configuration of Key Parts of Truck Attachments

1. Hydraulic system: the oil cylinders adopt originally imported hydraulic control check valves; all the seals adopt imported products; and the high-pressure rubber hoses adopt cone sealed high- performance imported rubber hoses.
2. Structural part: the fork carriages are welded by high-performance alloy steel plates.
3. Mechanical performance: it can realize 45°forward tilting and 19°backward tilting; and it adds hydraulic control check valves for the oil cylinders to realize holding pressure for a long time, and further ensure the safety at work or rubber hoses burst.
4. Applicable scope: it's applied to the transportation/tipping by clamping various round pieces of wood and round clothes, etc., which reduces the logistics costs and increases the production efficiency significantly.

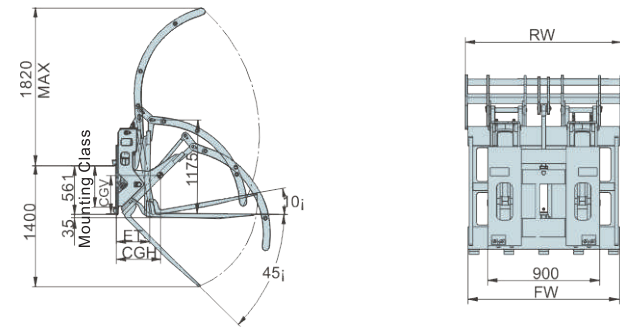

Capacity@ Load Center	Catalog Order No.	Mounting Class	Fork Length	Fork Width	Tilt Angles (Up/Down)	Raker	Raker	Effective Thickness	Vertical	Horizontal	Weight	Available Forklift
						width	Pivot Height		Center of Gravity	Center of Gravity		
(Kg@mm)			(mm)	(mm)	(mm)	(mm)	(mm)	(mm)	VCG (mm)	HCG (mm)		
2000@500	FC20Q-B2	III	Not equipped with fork	20° /45°	1170	760	375	365	395	580	3-4.5t	
2000@600	FC30Q-B1	III	1150	1200	10° /45°	1260	1175	390	370	480	860	3-4.5t
2000@600	FC30Q-B2	III	1400	1200	10° /45°	1260	1175	390	385	540	895	3-4.5t

Notes: 1. Please gain the actual overall carrying capacity of forklift trucks/attachments from the forklift truck manufacturers.  
 2. Forklift truck needs to add two groups of additional oil lines to match the attachments, and all the oil cylinders have self-locking functions.

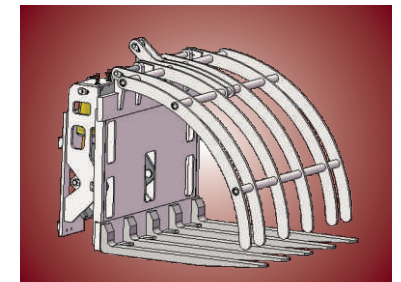

Model	Pressure Value Bar		Flow Value L/min		
	Min.	Max.	Min.	Recommend	Max.
	FC**Q	35	160	19	38

Configuration of Key Parts of Truck Attachments

1. Hydraulic system: the oil cylinders adopt originally imported hydraulic control check valves; all the seals adopt imported products; and the high-pressure rubber hoses adopt cone sealed high- performance imported rubber hoses.
2. Structural part: all the structural parts are welded by high-performance alloy steel plates.
3. Mechanical performance: it can realize 45°forward tilting and 10°backward tilting; and it adds hydraulic control check valves for the oil cylinders to realize holding pressure for a long time, and further ensure the safety at work or rubber hoses burst.
4. Applicable scope: it's applied to the transportation/tipping by clamping waste paper and other soft-material cargoes, which reduces the logistics costs and increases the production efficiency significantly.

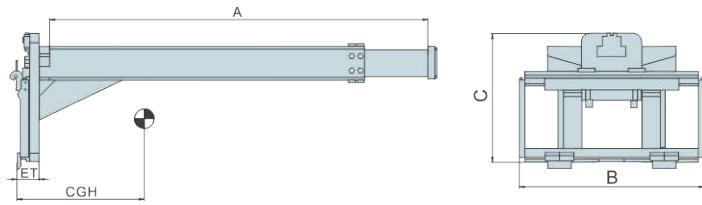

Capacity (Kg@mm)	Catalog Order No.	Truck Mounting Class	Total Reach <b>A</b> (mm)	Total Sideshift (mm)	Overall Width <b>B</b> (mm)	Overall Height <b>C</b> (mm)	Weight (kg)	Effective Thickness <b>ET</b> (mm)	Horizontal Center of Gravity <b>HCG</b> (mm)	Available Forklift (t)
2500@1100	<b>BL25G-B1</b>	III	1900-2595	200(±100)	1100	857	520	166	890	3-4.5t

- Notes: 1. Please gain the actual overall carrying capacity of forklift trucks/attachments from the forklift truck manufacturers.  
2. Forklift truck needs to add two groups of additional oil lines so as to match the attachments.

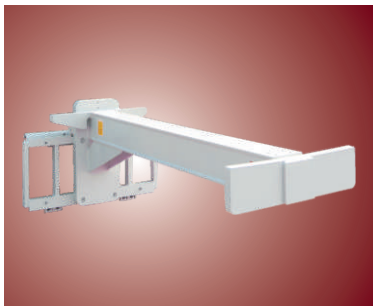

Model	Pressure Value Bar		Flow Value L/min		
	Min.	Max.	Min.	Recommend	Max.
<b>BL**G</b>	35	160	15	22	22

### Configuration of Key Parts of Truck Attachments

1. Hydraulic system: it's equipped with two-way hydraulic lock to realize two-way holding pressure; all the seals adopt imported products; and the high-pressure rubber hoses adopt cone sealed high-performance imported rubber hoses.
2. Mechanical performance: it's equipped with sideshifting function outside, and can move left and right 100mm respectively.
3. Applicable scope: it's applied to the handling operation of glass products, which reduces the logistics costs and increases the production efficiency significantly.

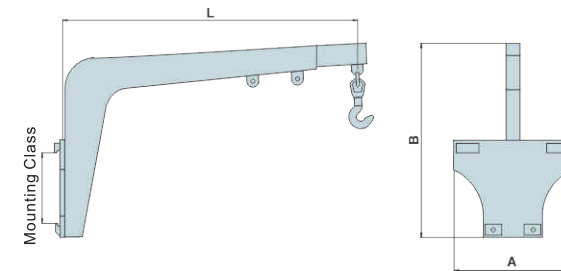

Capacity@ Load Center <b>Kg</b>	Catalog Order No.	Truck Mounting Class	Crane Jib type	Hook Number	Hoisting Position	Overall Width <b>A</b> (mm)	Overall Height <b>B</b> (mm)	Weight (kg)	Available Forklift (t)
1000	<b>QZ10G-X1</b>	Fork type	Single boom	1	1800、2000、2200 2400、2600、2800	485	658	250	1-7t
2500	<b>QZ25G-B2</b>	III	Single boom	1	1300、1600、2000 2300、2600	800	1335	300	3-4.5t
1500	<b>QZ15G-B1</b>	III	Single boom	1	1130	600	1800	250	3-4.5t
3000	<b>QZ30G-B5</b>	III	Single boom	1	1050、1550	600	1478	365	3-4.5t
2000	<b>QZ20G-B6</b>	III	Double boom boom	4	400、1400	1080	1475	365	3-4.5t
4000	<b>QZ40G-C1</b>	IV	Single boom	2	830、1630	600	1480	375	5-7t
3000	<b>QZ30G-C2</b>	IV	Double boom boom	2	1030、1880	1600	1300	880	5-7t



CJ16G-A1

ZK10Q-B1

GJ18J-A1

GJ18J-A2



FC30G-B1

CJ40G-C1

QF30F-B1

QF35F-B1



GC70

GC30

TL20C-B1

SC30D-B1



ZX07J-A1

RJ20ST-B1

RJ25ST-B2

SL15G-C2



XC15G-B1

YM45G-B1

RJ30RT-B1

ZK27G-B1



TJ14S-A1

TJ19R-A1

TJ19R-A2

TJ14S-B1



YT09G-A1

ZJ27R-B4

YX18G-A5

RJ25ST-B4



TY25G-A2

JC30Q-B1

YX18G-A9

HX05G-B1



FC20Q-B2

XZ10X-A1

RJ30ST-C1

LT12G-A1



YX18G-A6

QF30F-B1

RJ22ST-B1

ZB40G-C1