

CBD20/25/30-460

电动托盘搬运车 Electric pallet truck

产品性能特点:

- 驱动单元专利设计浮动机构;
- 电子助力转向, 轻便、静音;
- 交流驱动电机, 无碳刷、免维护;
- 电起升, 快速、高效, 标配起升限位装置;
- 蓄电池侧拉设计, 更换便捷、高效;
- 交流控制器, 无级调速, 动力强劲, 多重自动保护;
- 弯道自动减速功能, 更安全。
- 锂电款采用磷酸铁锂电池, 充电快, 效率高。

Characteristics:

- Drive unit floating bodies with patent design.
- Electronic power steering, light and low noise.
- AC driving motor without carbon brush and free maintenance.
- Electric lifting, rapid, efficient, electricity limit switch is STD.
- Side-way battery, easy to replace.
- AC controller, stepless, strong power, multiple automatic protection.
- Curve automatic deceleration function, safer.
- The LFP model lithium batteries are fast charging and efficient.



EPS AC

弯道自动减速 侧拉蓄电池

CBD20/25/30-460

制造商和技术参数 Manufacturer's Data and Design Characteristics

特性	Feature	单位	
1.1 型号	Model		CBD20/25/30
1.2 配置号	Configuration No.		460
1.3 额定载重	Load capacity	kg	2000/2500/3000
1.4 载荷中心距	Load center	mm	600
1.5 轴距	Wheel base	mm	1493
1.6 操作类型	Operating type		乘驾式 Stand on
车轮			
2.1 轮子类型(前/后)	Wheels type		PU
2.2 驱动轮/平衡轮/承重轮数量	Wheel quantity Driving wheel/Balance wheel/Bearing wheel		1/2/4
2.3 驱动轮尺寸	Driving wheel size	mm	Φ248×75
2.4 平衡轮尺寸	Balance wheel size	mm	Φ115×55
2.5 承重轮尺寸	Bearing wheel size	mm	Φ84×80
尺寸			
3.1 货叉最低离地高度	Min.fork lowered height	mm	85
3.2 货叉最大起升高度	Max.fork lifting height	mm	205
3.3 最大起升行程	Max.lifting height	mm	120
3.4 货叉外侧间距	Outside width between forks	mm	550/685
3.5 货叉内侧间距	Inside width between forks	mm	210/345
3.6 货叉长度	Fork length	mm	1150/1200
3.7 货叉宽度	Fork width	mm	170
3.8 货叉厚度	Fork thickness	mm	75
3.9 整车全长	Overall length	mm	1916/2333
3.10 车体宽度	Overall width	mm	790
3.11 整车高度(含手柄)	Overall height(With handle)	mm	1455
3.12 整车高度(不含手柄)	Overall height(Without handle)	mm	845
3.13 最小转弯半径	Min.Turning radius	mm	1746/2158
3.14 最小直角堆垛通道宽度 (托盘800×1200, 1200沿货叉放置)	Min.Aisle width for pallets 800×1200	mm	2046/2435
3.15 最小直角堆垛通道宽度 (托盘1000×1200, 1200沿货叉放置)	Min.Aisle width for pallets 1000×1200	mm	2077/2458
性能			
4.1 最大行驶速度, 满载/空载	Travel speed, laden/unladen	km/h	6/6
4.2 最大起升速度, 满载/空载	Lift speed, laden/unladen	mm/s	30/35
4.3 最大下降速度, 满载/空载	Lowering speed, laden/unladen	mm/s	40/35
4.4 爬坡度, 满载/空载	Gradeability, laden/unladen	%	6/16
电器配置			
5.1 驱动电机/起升电机/转向电机	Drive motor/ Lift motor	KW	AC1.5/DC1.2/DC0.15
5.2 制动	Brake		电磁/再生 Electromagnetic/Regenerative
电池 铅酸电池 锂电池(选配)		Battery	铅酸电池Lead-acid battery 锂电池Lithium battery (optional)
6.1 蓄电池电压/容量	Battery voltage/capacity	V/Ah	24/270 24/200
6.2 控制器	Controlller		ZAPI ZAPI
6.3 电池重量	Battery weight	kg	247 105
6.4 整车重量(包含蓄电池)	Service weight (with battery)	kg	831 675

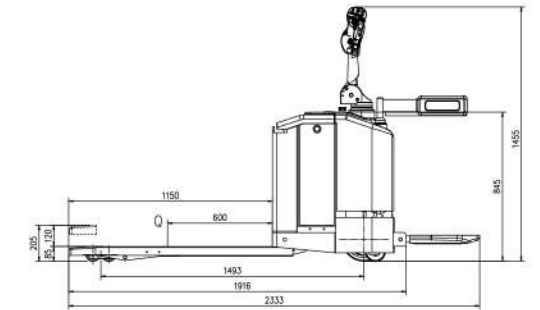
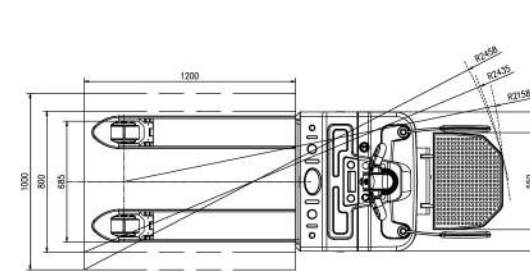

安徽合力股份有限公司
ANHUI HELI CO., LTD.
地址 / 中国 合肥方兴大道668号
Add / No.668, FangXing Road, Hefei, China
邮编 (Post Code) / 230000

客服热线 (Customer Service Hotline) / 4001-600761
服务电话 (Service Tel) / +86-551-63689000, 63648005