



TOP1 FORKLIFT MANUFACTURER AND SALER
IN CHINA FOR CONSECUTIVE 25 YEARS

CDD16/20

Forkover Electric Stacker

Lifting Height: 1400-5800mm

Load Curve

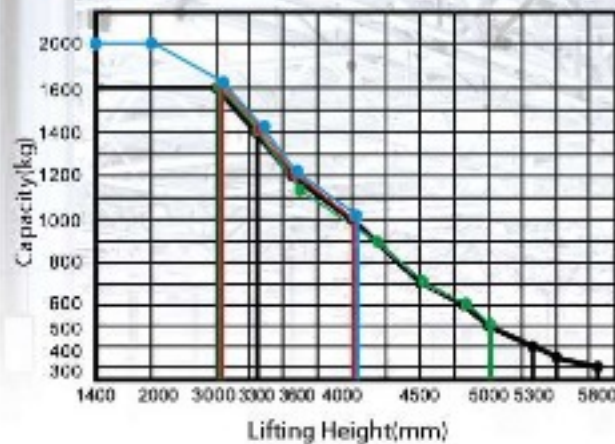

● CDD20-D930 ● CDD16-D930
● CDD16-950 ● CDD16-350



Advantages

Configuration and Performance

- Electronic power steering system, light and low noise.
- Two-way magnetic valve, three drop speed mode.
- Drive unit floating bodies with patent design.
- AC Driving system, No carbon brush, free maintenance.
- USA CURTIS driving controller.
- Electromagnetic, regenerative braking system.
- Automatic lifting limit, proximity switch, long life.

Safety

- Curve automatic deceleration devices, more safe.
- Vehicle decelerates automatically at higher position.
- Stepless speed control system, safe and quiet.
- Controller with Multiple automatic protection.
- Emergency reversing device/Emergency brake switch.
- High position automatic reduction device.

AC | EPS

Down mode at 3 speeds

Steering automatic deceleration

Truck automatically decelerates while at higher lifting position

Type	Lift height (mm)	Mast type	Outside width between legs (mm)	Inside width between legs (mm)
CDD16-D930	1400/2000/2500/3000/3300/3600/4000	Standard 2-STAGE	550/600/650/685	180/230/280/315
CDD16-950	3700/3900/4200/4500/4700/5000	FULL FREE 3-STAGE		
CDD16-350	5300/5500/5800	FULL FREE 3-STAGE		
CDD20-D930	1400/2000/2500/3000/3300/3600/4000	Standard 2-STAGE		

1. CDD20 Series, Lift height ≤ 2000mm, Load capacity is 2000kg.
2. CDD20 Series, Outside width between forks ≤ 650mm

Feature		CDD16	CDD20	CDD16	CDD16
Model		D930	D930	950	350
Configuration No.		D930	D930	950	350
Type		Narrow legs	Narrow legs	Narrow legs	Narrow legs
Mast type		Standard 2-Stage	Standard 2-Stage	Full free 3-Stage	Full free 3-Stage
Load capacity	kg	1600	2000	1600	1600
Load center	mm	600	600	600	600
Wheel base	mm	1325	1325	1375	1375
Operating type		Walkie/Stand On			
Wheels					
Wheels type		PU	PU	PU	PU
Wheel quantity/Driving wheel/		1/2/4	1/2/4	1/2/4	1/2/4
Balance wheel/Bearing wheel					
Dimension					
Standard lift height	mm	1400/2000/2500/3000/3300/3600/4000	1400/2000/2500/3000/3300/3600/4000	3700/3900/4200/4500/4700/5000	5300/5500/5800
Lowered fork height	mm	86	86	85	85
Fork size(length/width/thickness)	mm	1150/1220/185/55	1150/1220/185/55	1150/1220/185/55	1150/1220/185/55
Overall length	mm	2050/2470	2050/2470	2105/2525	2105/2525
Overall width	mm	856	856	957	957
Max. extend height	mm	1900/2500/3000/3500/3850/4100/4500	1900/2500/3000/3500/3800/4100/4500	4200/4400/4700/5000/5200/5500	5800/6000/6300
Mast lowered height	mm	1185/1535/1765/1980/2135/2335/2500	1185/1535/1765/1980/2135/2335/2500	2085/2135/2235	2520/2590/2690
Min. Turning radius	mm	1580/1990	1580/1990	1630/2040	1630/2040
Min. Aisle width for pallets 800×1200	mm	2180/2580	2180/2580	2230/2625	2230/2625
Min. Aisle width for pallets 1000×1200	mm	2210/2600	2210/2600	2260/2650	2260/2650
Min. ground clearance	mm	30	30	30	30
Performance					
Travel speed, laden/unladen	km/h	5/5	4/4.5	5/5	5/5
Lift speed, laden/unladen	mm/s	130/180	90/170	130/180	130/180
Lowering speed, laden/unladen	mm/s	100/230	80/170	100/160	100/160
Gradeability, laden/unladen	%	5/7	5/7	5/7	5/7
Electrical configuration					
Drive motor/Lift motor/Steering motor	kW	AC1.5/DC3/DC0.15	AC1.5/DC3/DC0.15	AC1.5/DC3/DC0.15	AC1.5/DC3/DC0.15
Battery voltage	V	24	24	24	24
Battery capacity	Ah	280	280	280	280
Brake		Electromagnetic/Regenerative			
Controller		CURTIS			
Weight					
Battery weight	kg	250	250	250	250
Service weight with battery	kg	1240	1240	1578	1610

* Details of specifications and equipment are based on information available at time of printing and may change without notice.

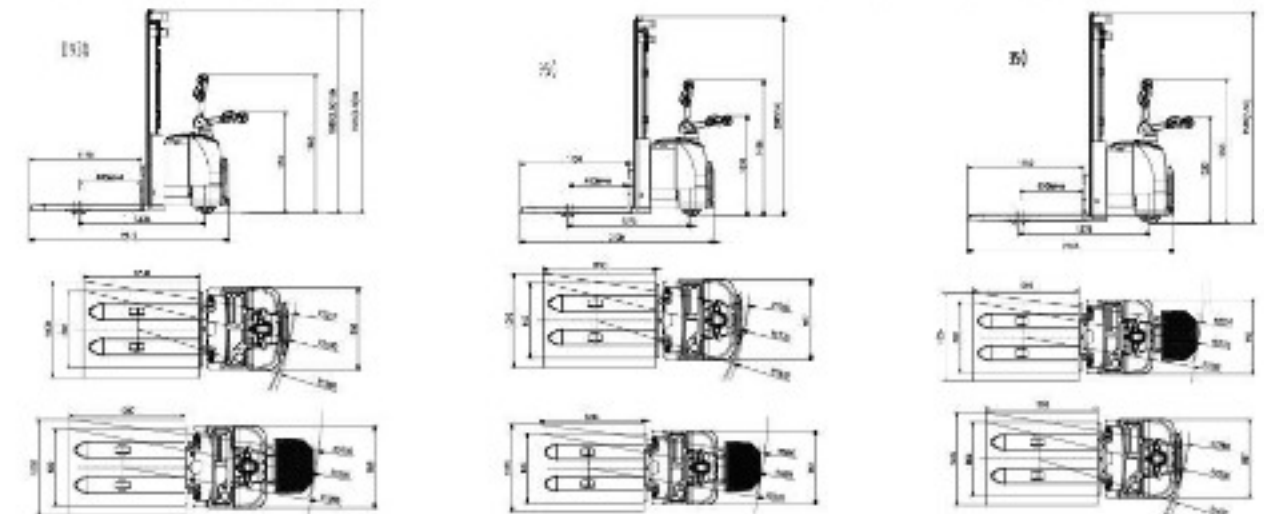

ANHUI HELI CO., LTD.

ADD: NO.668 Fangxing Street, Economical Development Zone, Hefei, P.R.China
TEL: (86 551) 63639068, 63639258, 63639358, 63662105, 63639530
FAX: (86 551) 63639966
WEBSITE: <http://www.helichina.net>
Email: heli@helichina.net

AUTHORIZED DEALER



TOP1 FORKLIFT MANUFACTURER AND SALES
IN CHINA FOR CONSECUTIVE 25 YEARS

CDD16

1.6 Ton Straddle Electric Stacker

Lifting Height: 1400-5800mm

Load Curve

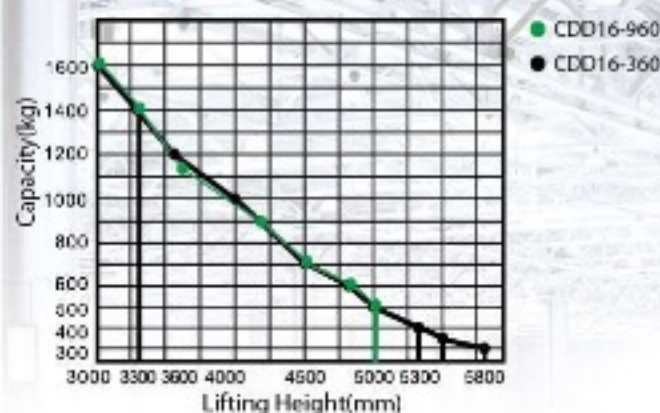

Advantages

Configuration and Performance

- ⊕ Electronic power steering system, light and low noise.
- ⊕ Two-way magnetic valve, three drop speed mode.
- ⊕ Drive unit floating bodies with patent design.
- ⊕ AC Driving system, No carbon brush, maintenance free.
- ⊕ USA CURTIS driving controller.
- ⊕ Electromagnetic, regenerative braking system.
- ⊕ Automatic lifting limit, proximity switch, long life.

Safety

- ⊕ Curve automatic deceleration devices, more safe.
- ⊕ Vehicle decelerates automatically at higher position.
- ⊕ Stepless speed control system, safe and quiet.
- ⊕ Controller with Multiple automatic protection.
- ⊕ Emergency reversing device/Emergency brake switch.
- ⊕ High position automatic reduction device.

Economical straddle typed stacker

Steering automatic deceleration

AC | EPS Down mode at 3 speeds

Truck automatically decelerates while at higher lifting position

Type	Lift height (mm)	Mast type	Outside width between legs (mm)	Inside width between legs (mm)
CDD16-960	3700/3900/4200/4500/4700/5000	FULL FREE 3-STAGE	1170/1320/1470/1650	970/1120/1270/1450
CDD16-360	5300/5500/5800	FULL FREE 3-STAGE		

Feature		CDD16	CDD16
Model		CDD16	CDD16
Configuration No.		960	360
Type		Wide legs	Wide legs
Mast type		Full free 3-Stage	Full free 3-Stage
Load capacity	kg	1600	1600
Load center	mm	600	600
Wheel base	mm	1375	1375
Operating type		Walkie/Stand On	
Wheels			
Wheels type		PU	PU
Wheel quantity/Driving wheel/		1/2/4	1/2/4
Balance wheel/Bearing wheel			
Dimension			
Standard lift height	mm	3700/3900/4200/4500/4700/5000	5300/5500/5800
Lowered fork height	mm	55	85
Fork size(length/width/thickness)	mm	1070/100/40	1070/100/40
Overall length	mm	2073/2493	2073/2493
Overall width	mm	1470	1470
Max.extend height	mm	4200/4400/4700/5000/5300/5500	5800/6000/6300
Mast lowered height	mm	1500/1900/1985/2068/2135/2235	2520/2590/2690
Min.Turning radius	mm	1630/2040	1630/2040
Min.Aisle width for pallets 800×1200	mm	2230/2625	2230/2625
Min.Aisle width for pallets 1000×1200	mm	2260/2650	2260/2650
Min.ground clearance	mm	50	30
Performance			
Travel speed,laden/unladen	km/h	5/5	5/5
Lift speed,laden/unladen	mm/s	130/180	130/180
Lowering speed,laden/unladen	mm/s	100/200	100/200
Gradeability,laden/unladen	%	5/7	5/7
Electrical configuration			
Drive motor/Lift motor/Steering motor	kW	AC1.5/DC3/DC0.15	AC1.5/DC3/DC0.15
Battery voltage	V	24	24
Battery capacity	Ah	280	280
Brake Controller		Electromagnetic/Regenerative CURTIS	
Weight			
Battery weight	kg	250	250
Service weight with battery	kg	1648	1680

* Details of specifications and equipment are based on information available at time of printing and may change without notice.

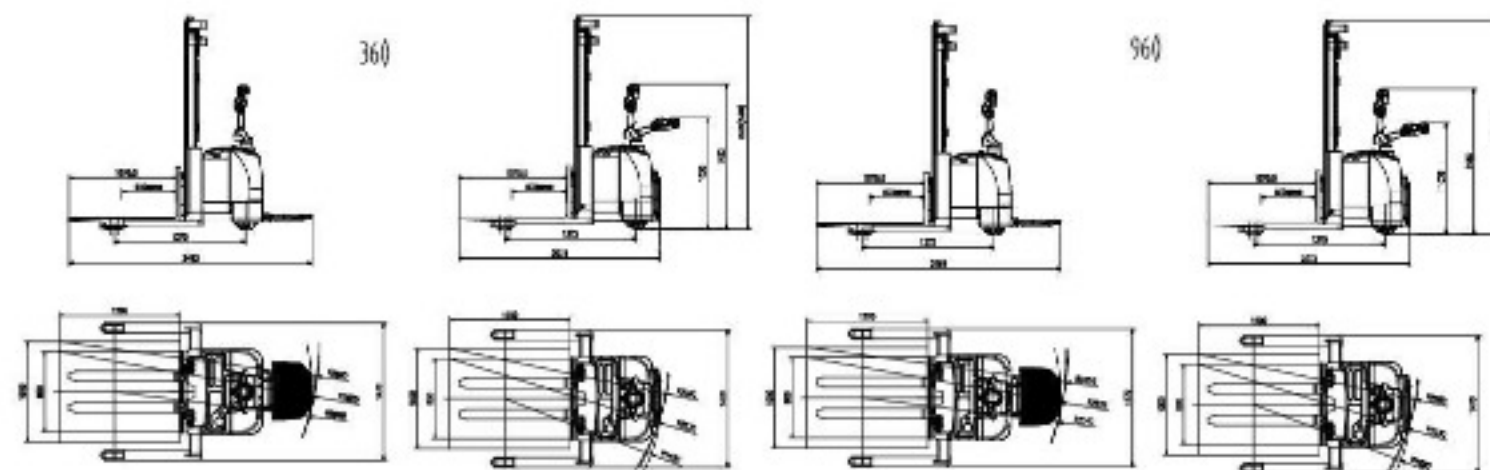

ANHUI HELI CO., LTD.

ADD: NO.668 Fangxing Street, Economical Development Zone, Hefei, P.R.China
TEL: (86 551) 63639068, 63639258, 63639358, 63662105, 63639530
FAX: (86 551) 63639966
WEBSITE: <http://www.helichina.net>
Email: heli@helichina.net

AUTHORIZED DEALER